

SERVICE MANUAL

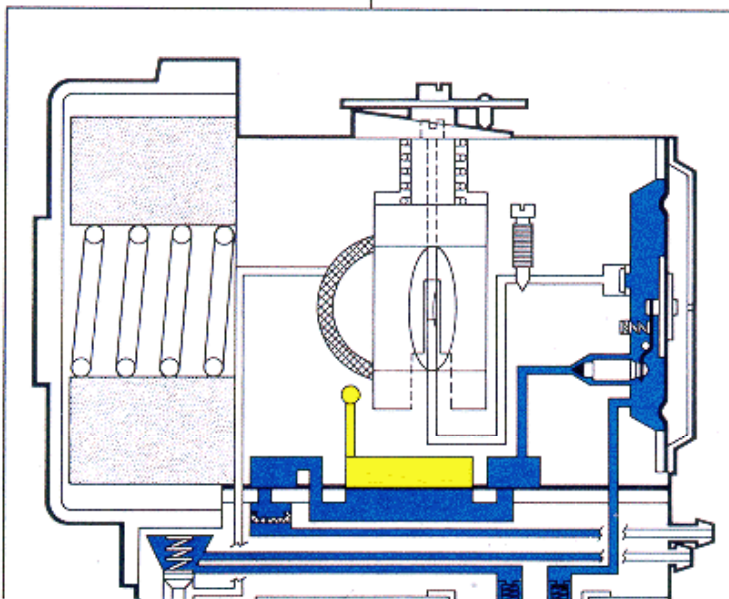

Walbro DIAPHRAGM CARBURETORS

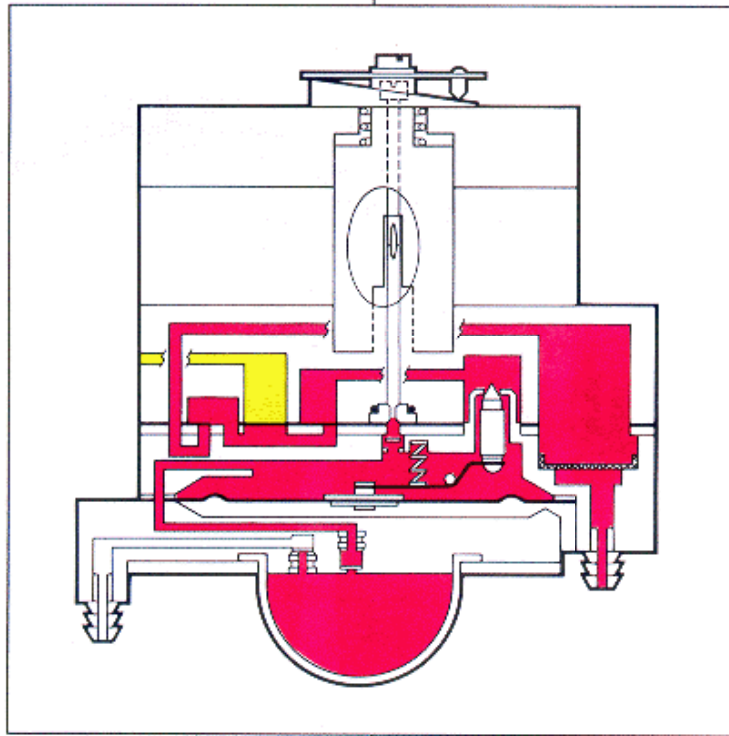
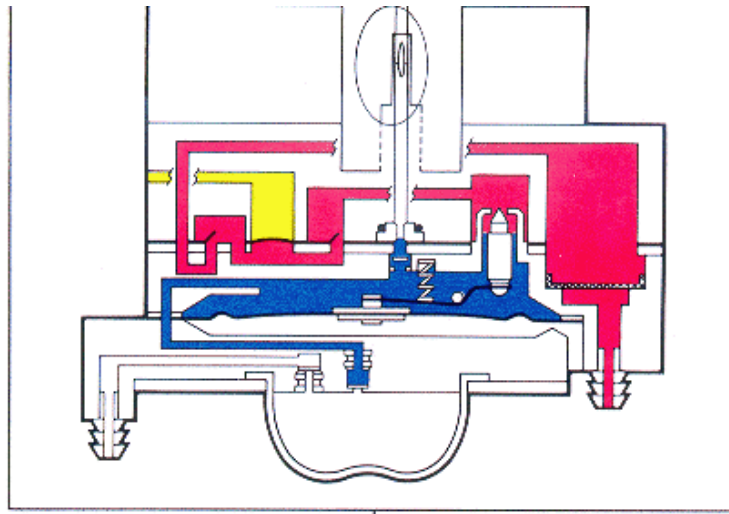

Walbro
Engine Management
Aftermarket Division

INTRODUCTION.....	2
AIR AND FUEL.....	3
ALTERNATIVE FUELS.....	4
TWO-CYCLE ENGINES.....	5,6
THE FUEL METERING SYSTEM.....	6,7
BUTTERFLY VALVE CARBURETORS.....	7,8
VENTURI OPERATION.....	8
TROUBLESHOOTING.....	9-12
Determining Cause.....	9,10
Pressure Testing.....	11
Hard Starting Hot.....	11
No Idle.....	11
Poor Idle.....	12
Poor Acceleration.....	12
Poor High Speed.....	12
Carburetor Disassembly.....	12,13
CARBURETOR REBUILD.....	13,14
Mixture Screws.....	13
Fuel Pump.....	14
Welch Plug Removal.....	14
Circuit Plate Removal.....	14
MAIN NOZZLE CHECK VALVE.....	15-17
REASSEMBLY.....	18
PRESSURE TESTING.....	19
ADJUSTMENTS.....	20
BARREL VALVE CARBURETORS.....	21
WY SERIES.....	22
WZ SERIES.....	23
BARREL VALVE CARBURETOR ADJUSTMENTS.....	24
AIR PURGE SYSTEMS.....	25
PRIMER SYSTEMS.....	26, 27
ACCELERATOR SYSTEMS.....	28, 29
GOVERNOR.....	30
TOOLS.....	31

As diverse as the Walbro diaphragm carburetor line has become, producing a manual to detail the repair of each specific Walbro carburetor would be a monumental task, and the manual would be obsolete as soon as it was printed. Instead, what we hope to do here is to show you the individual components that are found in various combinations within our carburetors and show you how to troubleshoot and service them.

We hope this manual becomes a useful and profitable tool in your shop. As we develop new carburetor technologies, we will try to keep you up to date on further service techniques. If you have any suggestions or additions to the next printing, please send us a note.

Sincerely,

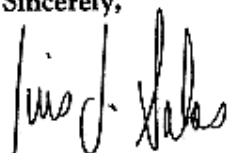

Luis J. Salas
Field Service Supervisor
Aftermarket Division
Walbro Engine Management Corp.

The Air

Air taken into an engine is what actually creates the power within the engine. Of course, the air is useless without fuel. Fuel burning causes the air to heat and expand creating the power of the engine. The amount of power created is a function of the amount of air taken into the cylinder. If a small amount of air is drawn into the cylinder, the air density is low and a small amount of power is produced. Since the engine is under a certain amount of internal and external drag, the power produced slightly overcomes the drag and the engine runs slowly. As more air is admitted into the cylinder the air density becomes higher and more power is produced. The engine runs faster, or can carry a bigger load.

The air is not sucked into the cylinder, it is pushed in by atmospheric pressure. At sea level atmospheric pressure exerts 14.7 PSI upon everything around it. Of course, as you come up from the sea atmospheric pressure drops - enough so that for every 1,000 feet above sea level an engine loses about 3.5% of its power.

Anything that allows more air to be pushed into the engine on the intake stroke will increase the engine's power. A turbo or super charger increases air density by packing the air in tighter than atmospheric pressure can. Similarly, decreasing the air temperature increases air density, so colder air produces more power than hot air.

The Fuels

For any fuel to burn most efficiently it must be combined with a specific amount of air. This specific air/fuel ratio is called the stoichiometric. (Impress your friends with that one!) For gasoline, the best ratio is 14.6 lbs. of air for each pound of gasoline. At this ratio all the available air is combined with all the available gasoline to get the most power and least emissions out of the engine. Unfortunately, an engine will not survive running at this 14.6:1 ratio; it would quickly overheat. For an engine to survive, it must run an air/fuel ratio that is a bit richer.

A rich mixture contains more fuel than the "ideal". Most engines run at a ratio of 10.5:1 to 12:1, providing them with a bit of excess fuel. The extra fuel is used to cool the cylinder components as the engine runs. Since some fuel is being wasted at a rich setting, emissions are higher and power is slightly less; we want the engine to run just rich enough to keep cool. This is the mixture at which the carburetor is generally set.

Opposite of a rich mixture is a lean mixture - too much air and not enough fuel. Again, running lean will overheat the engine. Hot engines lose their operating tolerances and seize. Hot engines are also prone to detonation, an explosive uneven burning of the fuel within the cylinder. Detonation puts extreme loads on engine parts causing them to fail.

Alternative Fuels

The other two fuels that are sometimes used (generally as high performance alternatives to gasoline) are the alcohols: methanol and ethanol. Both of these fuels require a much richer mixture than gasoline. Methanol needs an air:fuel ratio of 6.4:1, or about 2.25 times more fuel-to-air than gasoline. Ethanol requires an air:fuel ratio of 9:1, or about 1.6 times the fuel-to-air of gasoline.

So if it takes so much more alcohol to get the same power as gasoline, why is it used as a high performance fuel?

First, alcohols have a much higher octane than gasoline, and an engine can be built to run at higher compression ratios without detonation, so the engine can produce more power. NOTE: This offers no benefit for a standard gasoline engine.

Second, alcohols have a higher latent heat of evaporation. In other words, it takes more heat to evaporate alcohol than gasoline. Notice how cool a running carburetor gets; it takes heat to vaporize any liquid. Alcohol takes the heat from the intake air (the cooled air is denser) and the dense air packs the cylinder tighter, resulting in more power. An engine running on 100% methanol will produce about 15% more power than when running on gasoline. Of course, it will also burn over twice as much fuel to get that extra 15%.

Third, alcohol fueled engines run cooler than gasoline engines. But keep in mind that if an engine is run on alcohol while the carburetor is set for gasoline, the engine will be running *leaner* and *hotter*.

Walbro carburetors can tolerate the legal limits of alcohols present in today's fuels: 10% ethanol, 5% methanol, and 11% of the octane enhancer MTBE (Methyl Tertiary Butyl Ether). Careless blending can sometimes result in percentages exceeding these levels on a local basis. You may have noticed that the material at the tip of the inlet needles is now a red colored viton, and that several fuel pump diaphragms are now made from a brown colored woven fiberglass. These new components were developed to increase the alcohol resistance of our carburetors. No carburetor will currently handle 100% alcohol fuels for an extended period. If you wish to use alcohol in a high performance application, we recommend you contact a local race shop for advice on carburetor modifications.

You can see from this short discussion on air and fuel that the carburetor has an important job. Not only does it maintain a constant proper air:fuel ratio, it must do so throughout all the various speeds, loads, and running conditions that the engine faces. We are now ready to continue on and learn how it accomplishes this.

Air Induction on the Two-Cycle Engine

There are three basic forms of induction on the 2-cycle engine: rotary valve, reed valve and piston ported. We'll discuss reed valve and piston port here since these are the most common in the small engine industry. Rotary valves are generally found only on motorcycles and snowmobiles.

The low pressure needed to draw air through the carburetor is created by the motion of the piston, but in the 2-cycle engine the air is drawn in below the piston into the crankcase. This is known as crankcase pumping. Crankcase pumping is created by the pistons and the rings, and is maintained by the crankshaft seals and gaskets, and the cylinder gasket. On the reed valve style engine a thin metal or plastic reed is used to ensure that the air only flows in through the carburetor, and doesn't flow back out on the downward stroke of the piston. The piston ported engine allows the piston skirt to provide this function of the one-way valve.

One big advantage of the 2-cycle engine, since it doesn't rely on an oil sump for lubrication, is its ability to operate in any position. To make use of this feature, we must also have a carburetor which can operate in any position. In order to operate in any position, the systems normally depending on gravity (namely the float and inlet needle, and the gravity flow fuel system) need to be replaced with mechanical devices. The diaphragm carburetor replaces the float with a metering diaphragm and uses a fuel pump in place of gravity feed.

The Fuel Pump System

The power to operate the fuel pump comes from the crankcase impulse. The pressure and vacuum pulses travel through either a drilled passage or an impulse line. The pump is made up of the diaphragm bubble and a series of check valves. The fuel pump provides pressure which the rest of the carburetor depends on. As the piston moves up into the cylinder it creates a low pressure area in the crankcase. This vacuum pulse travels through the impulse passage and draws up on the pump diaphragm creating a vacuum within the fuel chamber. Atmospheric air pressure is allowed into the fuel tank and pushes the fuel through the fuel filter, the fuel line, and opens the inlet check valve to fill the vacuum. The vacuum closes the fuel pump's discharge check valve.

REED VALVE INDUCTION

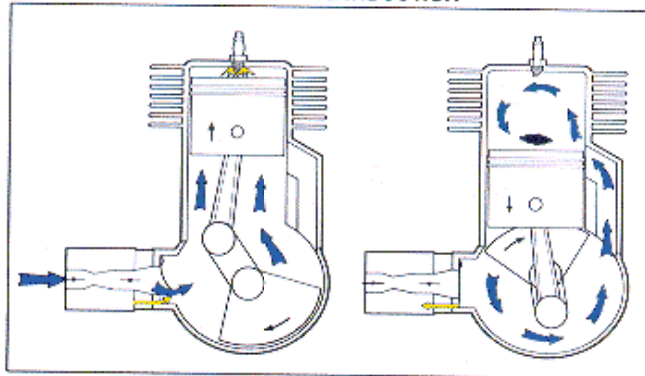

As the piston moves up, atmospheric air (blue) travels through the carburetor and picks up gasoline. It opens the reed valve and enters the low pressure of the crankcase.

As the piston moves down, pressurizing the crankcase, the air and fuel are pushed through the transfer ports to the combustion chamber, and the pressure in the crankcase closes the reed valve.

PISTON PORT INDUCTION

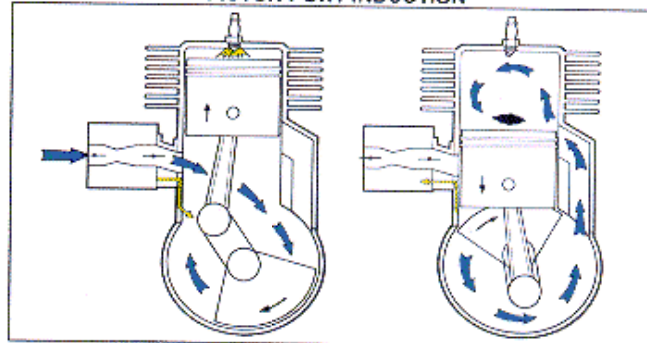

As the piston moves up, atmospheric air travels through the carburetor and picks up gasoline once the piston skirt passes the intake port.

As the piston moves down, pressurizing the crankcase, the air and fuel are pushed through the transfer ports to the combustion chamber once the piston skirt seals the intake port and the piston top opens the transfer port.

FUEL PUMP

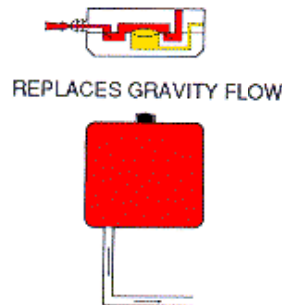

METERING DIAPHRAGM

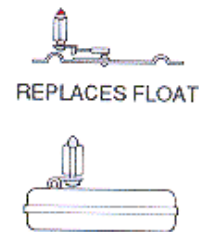

FUEL PUMP INTAKE

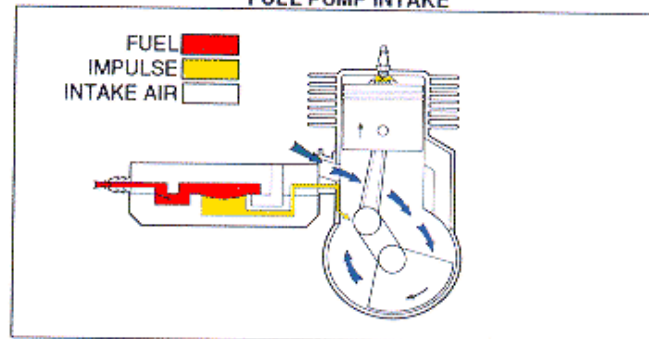

FUEL PUMP DISCHARGE

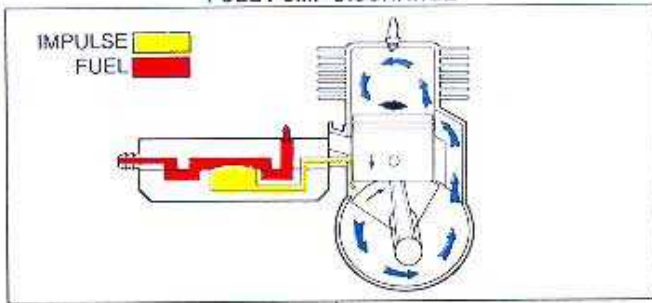

As the piston moves down into the crankcase it pressurizes the air. The pressurized air travels through the impulse passage into the carburetor fuel pump; it then presses down on the diaphragm pressurizing the fuel. The pressurized fuel then closes the inlet valve and opens the discharge valve in the fuel pump.

From the pump, the fuel travels to the fuel inlet screen. The screen has an important job as the final protection against dirt in the inlet needle and the seat. The inlet screen is sized in conjunction with the fuel filter selected by the engine manufacturer.

The inlet needle and seat control fuel flow through the carburetor. It is essential that they be in good condition for the carburetor to function properly. The actual seating area needs to be quite small to seal back the pressure from the fuel pump. Because of the small seat area, the inlet needle and seat are susceptible to leaking caused by dirt and debris. Walbro carburetors will either have a machined-in aluminum seat or a pressed-in brass seat. The pressed-in seat is used only for ease of manufacturing; it should not be pressed out for service.

The Fuel Metering System

There are four components to the fuel metering system: 1) the Metering Diaphragm; 2) the Metering Lever; 3) the Metering Spring; and 4) the Inlet Needle. The metering diaphragm is a very sensitive device. It must respond instantly to slight changes in the fuel vacuum within the metering chamber. The diaphragm is made of a nitrile rubber compound over woven silk, with the convolution molded in to allow for greater movement. A stiffener plate and button are attached at the center. Because the diaphragm must respond to each intake stroke of the engine, it must be of the proper weight and resiliency. If it is too stiff or too heavy, it will not respond fast enough and the engine will starve for fuel at high speeds.

The metering lever transfers the pressure of the spring to the inlet needle, holding the needle closed and preventing fuel from flowing from the pump. When the engine is running, the metering lever does not lift the needle off the seat; since the needle tip is under pressure from the fuel pump, it lifts off the seat as soon as the metering diaphragm travels far enough down to override the spring force. Metering lever height is very important in controlling when and how far the inlet needle opens. If the lever is set too high, the engine may run rich; if it is too low the engine will run lean.

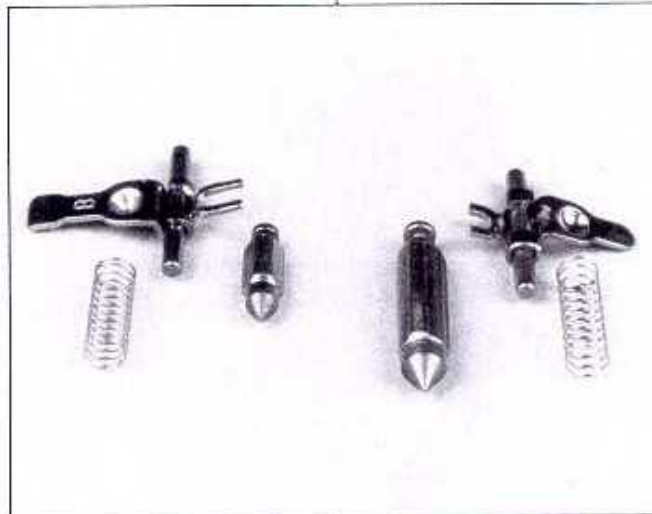
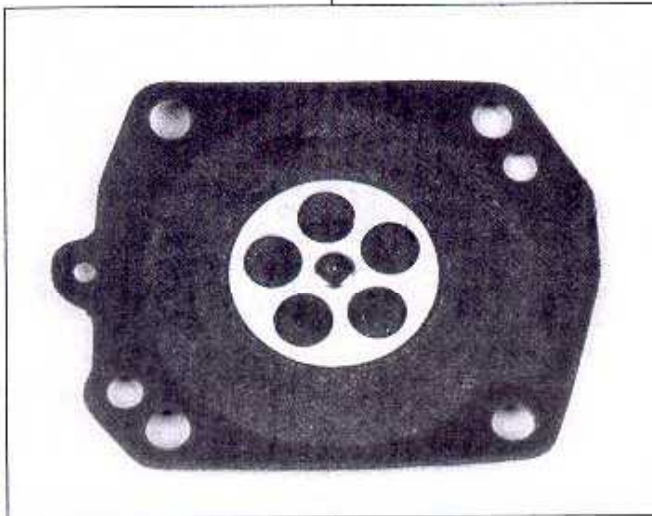

The metering spring does more than simply close the inlet needle. It also helps determine the acceleration and deceleration characteristics of the engine. The spring must allow the valve to open at just the right moment on acceleration or the engine will stumble, and it must close at the right time when the throttle is closed or the engine will flood. Therefore, it is important to maintain the proper metering spring in the carburetor. We'll look at the metering system as it functions with the entire carburetor.



400 - 606 Spring Kit

Start Up

The engine at start up has a number of requirements that differ from usual operation. The engine is often times cold; a cold engine is not as efficient at vaporizing fuel because heat is required to vaporize liquid. Cranking speeds are much lower than running speeds, so air flow through the carburetor is not strong enough to make fuel flow into the air stream. Fortunately these two problems can be overcome by creating a rich fuel/air mixture. This is done with either a primer - which injects extra gasoline into the carburetor throat - or a choke which greatly increases the vacuum in the carb throat allowing an unusually high amount of gasoline to enter the intake air. With the choke closed, the intake vacuum of the engine is maintained within the carburetor throat. This high vacuum causes all the carburetor's fuel nozzles to deliver the fuel into the intake air stream.

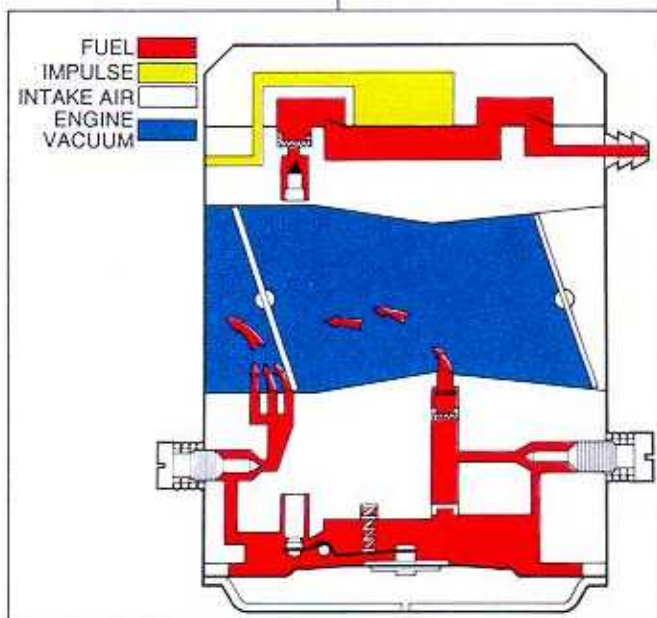

Idle

Once the engine starts, the choke is opened and the engine is idling. At idle, the throttle plate is nearly closed. There is low pressure on the engine side of the plate and high pressure (atmospheric pressure) on the other side. The high pressure air flows into the remaining transition holes and mixes with the fuel in the idle pocket. Fuel is drawn out of the idle pocket into the low pressure ~~on the engine~~ side of the throttle plate. As the fuel is drawn out of the idle pocket it creates a low pressure throughout the metering system. Atmospheric air enters through the vent and presses on the metering diaphragm. The diaphragm presses on the metering level, releasing the spring pressure off the inlet needle allowing enough fuel to come in to replace the fuel drawn out on that stroke.

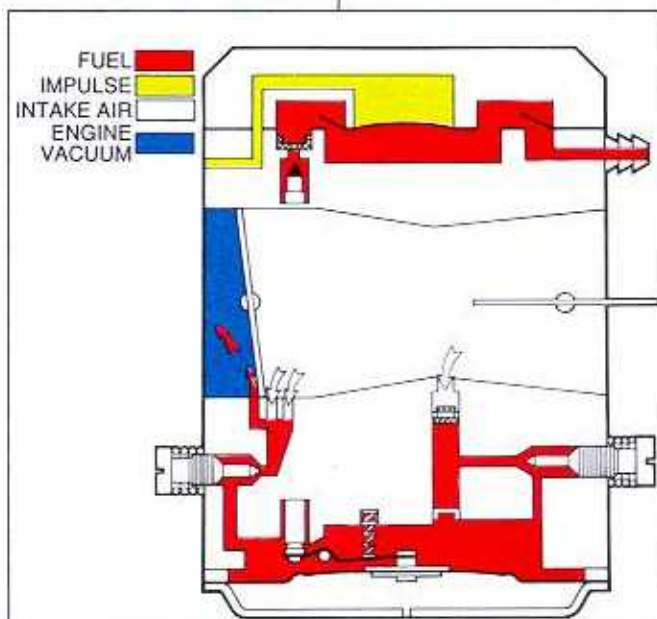

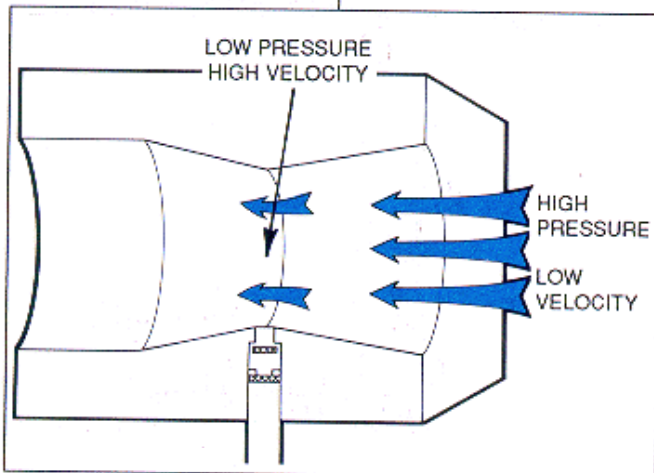
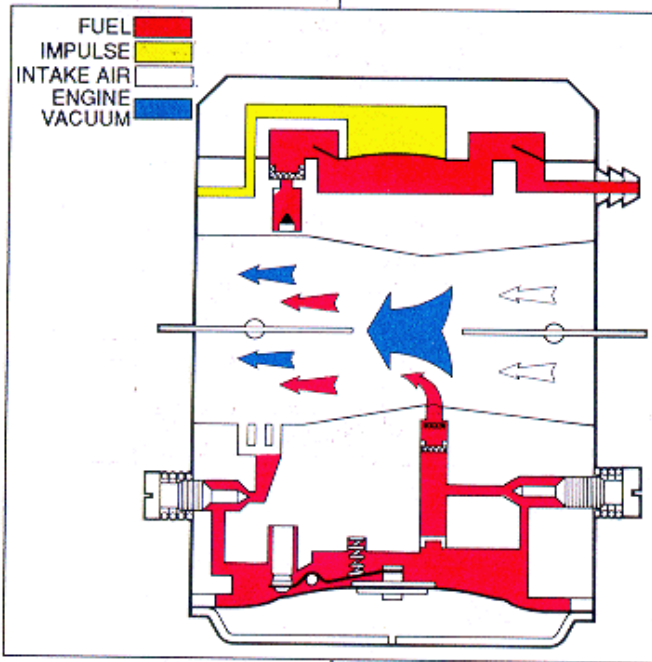
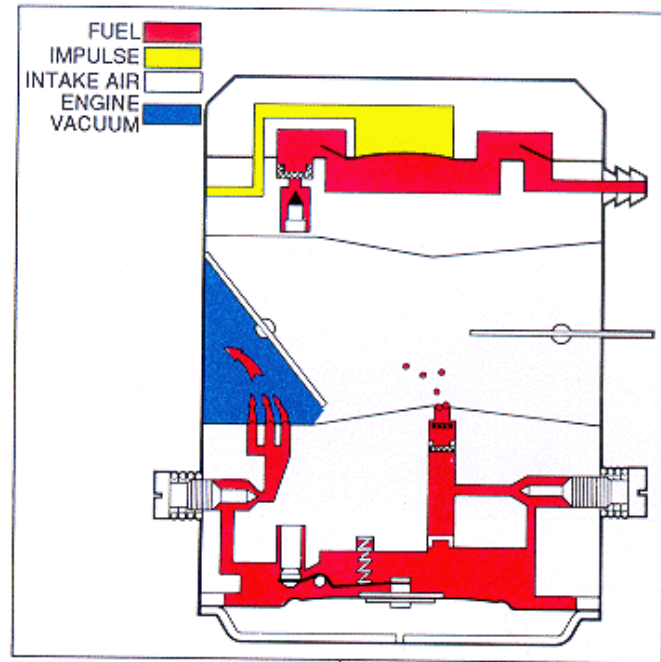

Part Throttle

At moderate throttle settings, the throttle plate has opened farther to allow increased air into the combustion chamber. In order to maintain the proper air/fuel mixture, additional fuel must be mixed in. This fuel comes from the idle progression holes. On most diaphragm carburetors no air comes out of the progression holes at part throttle. There are some diaphragm carburetors that do have an air bleed for the idle circuit. These usually appear as a small hole leading from the outside of the carb body into the idle pocket. The air bleed helps to atomize the fuel and helps prevent intake manifold puddling. Puddling is the buildup of gasoline in a pool, which then gets sucked into the engine and causes the engine to go rich. At part throttle the main nozzle begins to contribute fuel.

Wide-Open Throttle Operation

As the throttle plate is opened farther, it has less effect on the location of the high and low pressure areas within the carburetor throat. At wide-open throttle, air quickly rushes through the carburetor to fill the cylinder. Since air refills the cylinder soon after the intake vacuum is created, there is not much low pressure air (vacuum) within the carburetor throat. A low pressure area must be created within the throat to draw fuel into the air stream. This low pressure is created with a venturi. NOTE: Depending on the carburetor design, the idle circuit may or may not deliver fuel at wide-open throttle.

Operation of a Venturi

We attempt to force the same amount of air through the restriction of the venturi as is "naturally" flowing through the larger front and back of the carburetor throat. To get the same amount of air through a smaller hole, the air must speed up. As it speeds up, its pressure drops. This low pressure created at the venturi draws fuel out of the main nozzle.

The high speed nozzle is positioned so the venturi vacuum draws fuel into the carburetor throat.

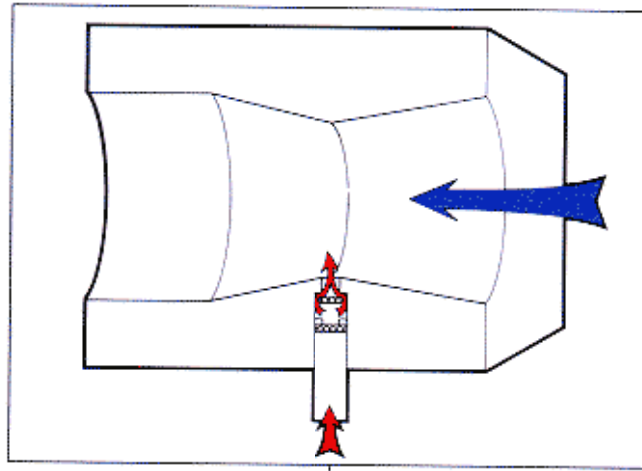

Main Nozzle Check Valve

The main nozzle is under atmospheric pressure when the engine is at idle and low throttle, and it's under a vacuum when the engine is at medium and full throttle. To prevent the high pressure air at idle from bleeding back into the fuel passages (which would disrupt the idle mixture), we must place a check valve in the high speed fuel passage (usually right at the main nozzle). The check valve allows the fuel to leave the main nozzle, but does not allow air to come in.

We have looked at what happens within the carburetor as it runs from start up to wide-open throttle, now we'll look at troubleshooting carburetor problems and components.

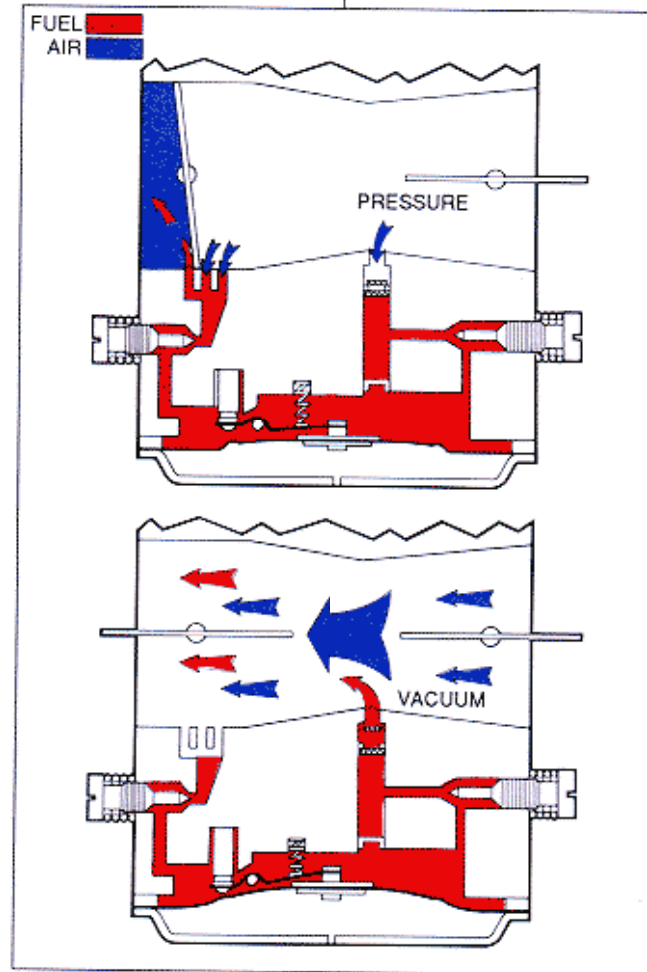

Troubleshooting Carburetor Problems

Since the carburetor is so dependent on the operation of the engine to do its job, your first step in troubleshooting is to determine if you have a carburetor or an engine-caused problem. We will assume you have already performed the needed tests on the ignition and compression systems, as problems within these systems can be mistaken for carburetor problems. It is helpful to be able to test the intake systems

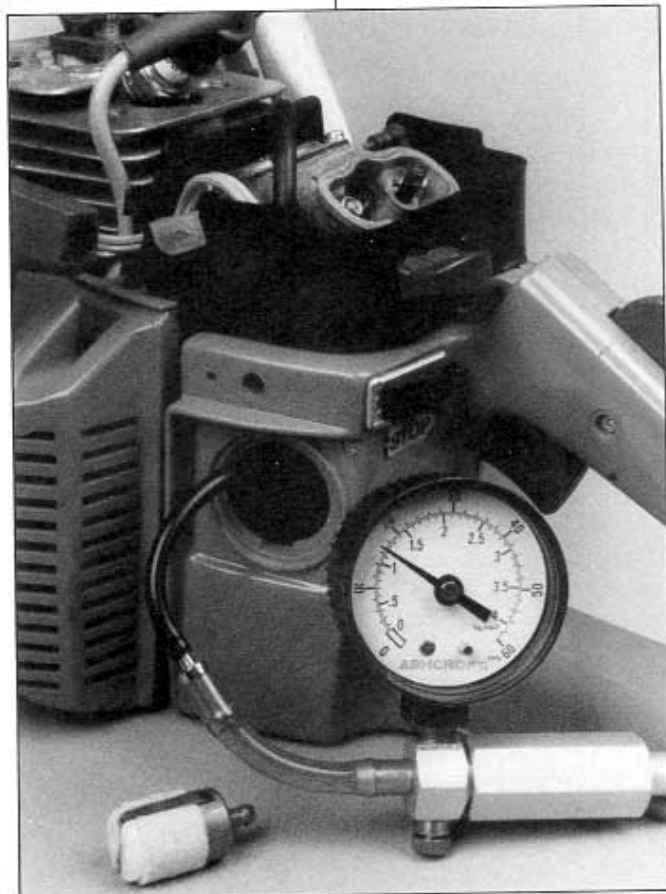
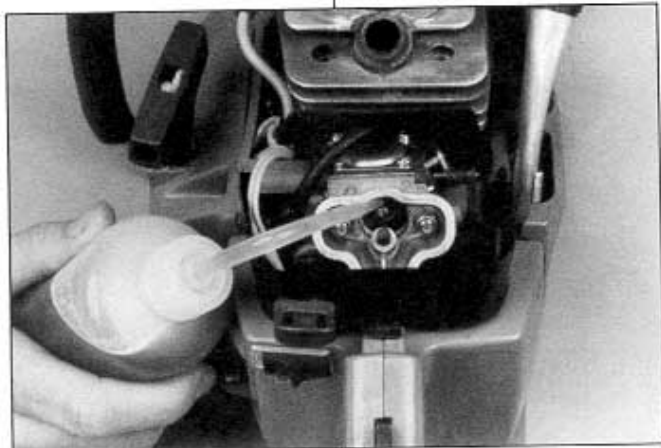
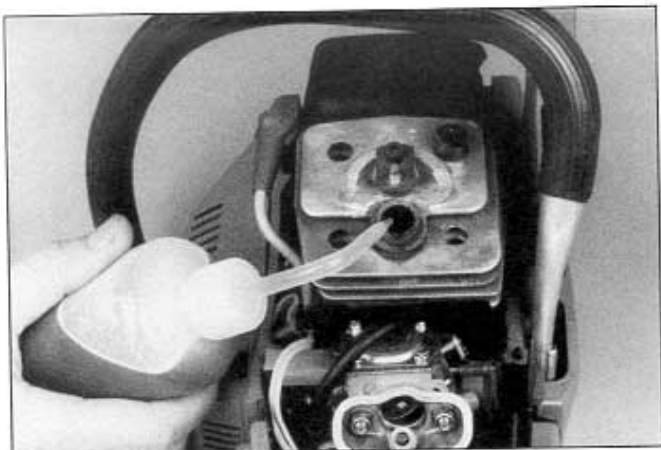

Pressure testing the fuel system.

for proper operation. On a four-stroke engine, performing a leak-down test is quite helpful. On a two-stroke engine, performing a vacuum test on the crankcase is necessary. In the absence of these tests you cannot be sure whether you are dealing with a carburetor or an engine induction problem. In the absence of a leak-down gauge or a crankcase vacuum pump, the following tests can help pinpoint carburetor or intake problems:

- A good first test is to spray some fuel into the spark plug hole, reinstall the plug, and try to start the engine. If the engine fires, you can assume that ignition and compression are operational.
- Next, spray some fuel into the carb throat. If the engine fires again, you can be pretty sure that the problem is in the carburetor, or at least the fuel system. If the engine still doesn't fire, you will need to inspect the intake system and the other components of the engine.
- If the spark plug is wet even though the ignition is good, the engine is getting too much fuel to run, or the plug is wet with something other than fuel.

So now if you're sure that the carburetor is causing the problem, you can begin to troubleshoot the carburetor.

• Proper thorough troubleshooting can only be done in a systematic way, starting with the easiest things to check and moving on to the more difficult. On a carburetor, the check list from easiest to more difficult may look like this:

1. Mixture screw settings
2. Fuel level and quality (drain tank)
3. Fuel tank venting
4. Fuel filter (replace)
5. Throttle and choke linkages
6. Air cleaner

Pressure Testing

Pressurize the entire fuel system with the 57-11 pump and gauge. You should get a pop-off and a re-seat pressure. This checks the following things: fuel line for leaks and soft spots; fuel pumps for sticking valves and plugged inlet screen; inlet needle for proper pop-off and re-seat.

As you have the pressure tester hooked up to the fuel line, crank the engine over. On each intake stroke, the needle on the 57-11 gauge should drop. This indicates that the metering diaphragm is allowing the needle to open and air is passing through the carburetor fuel passages into the throat. You may have to choke the carburetor to perform this test.

Pop-off and re-seat pressures are not critical components of carburetor troubleshooting. You are placing the carburetor in a very unnatural situation by pressurizing it with 30 pounds of air. Pop-off and re-seat pressures may vary by 10 or more PSI from carburetor to carburetor. The important thing is that the needle does pop off at some point, and the re-seat pressures be 10 PSI or above. This will ensure that the fuel pump pressure does not override the needle since the pump produces 5-7 PSI.

Refer to the troubleshooting chart in the back of this manual to help you determine the possible cause of a problem. Detailed below are some fuel systems problems that are not specifically listed on the chart.

Hard Starting Hot

Hot restart problems can often times be traced to vapor lock in the carb or fuel line. Vapor lock occurs when the fuel lines or the carburetor are heated above normal temperatures after the engine is shut off, and the liquid fuel turns to vapor. Inspect the exhaust system and air shields for damage. Make certain the insulator blocks and gaskets are the proper ones for your engine. This problem can be compounded by the wrong season blend of fuel. A cold weather fuel will vaporize too easily in the heat. Another heat-related problem can result in the fuel in the tank pressurizing the carburetor to the point of the needle coming unseated, causing carburetor leakage and engine flooding. This problem can occur more rapidly with an alcohol blend. A rich adjusted carburetor will compound a hot start problem by delivering even more fuel into an already rich engine. Different engines require various amounts of choke to start up hot. Some will flood too easily when hot; others may require choking to draw a vapor lock through the carburetor. Unfortunately, these insights into what the engine "likes" can only come through experience with that engine.

No Idle

An engine that fails to idle could be caused by several problems. Is the idle speed too low? Is there excess drag on the engine? Poor crank seals or poor compression will ruin the idle. Carburetor problems



When pressure testing the fuel system, you need not wait for the inlet needle to pop off. You can open the inlet needle by cranking the engine or by tickling the metering diaphragm through the atmospheric vent hole. If the inlet needle re-seats below 10 psi, or does not re-seat, follow the procedures on p. 17 & 18.

List the causes you have found which contribute to the following problems:

that will ruin the idle are: clogged idle circuits and progression holes; misadjusted idle mixture screws; air leaks at the carburetor mounting gaskets; and leaking main nozzle check valves. A metering lever set too high will cause the main nozzle to drip and produce an erratic, rich idle, as will the wrong metering spring.

Poor Idle

A lot of poor idle problems can be traced to fuel puddling. Fuel puddling occurs when fuel vapor comes out of suspension and forms pools of liquid gasoline in the crankcase of a two-stroke engine, or the intake tract. Some puddling is inevitable, as some fuel will be knocked out of suspension by the crankshaft and connecting rod. The swirling of the fuel within the crankcase can also lead to puddling. Puddling causes problems when the engine is moved or turned and the raw fuel is ingested into the combustion chamber. A rich idle mixture can aggravate fuel puddling, as will a high metering lever, pressurized fuel tank, or a dirty air cleaner. Usually a fuel puddling problem needs to be corrected by a better internal engine design, but the problem is aggravated by poor carburation.

Poor Acceleration

If the carburetor has an accelerator pump, you will need to determine that it is working properly. Refer to the Accelerator Systems section of this manual. Most engines accelerate off a slightly rich idle mixture. If the idle mixture is adjusted for the perfect idle, that's probably too lean for good acceleration. If the metering lever is too low, or the metering spring is too stiff, the mixture will be too lean for acceleration.

Poor High Speed

The increased demand for fuel at high speed operation can overload the capacity of a dirty fuel system or inlet screen. Soft fuel lines have a tendency to collapse under the increased draw at high speed. A poorly ventilated tank will cause high speed fuel starvation. A sticky main nozzle valve or one swollen from stale fuels will not allow gasoline through the high speed system. A governor on the carburetor or ignition will give the effect of poor high speed performance when the engine overruns.

Carburetor Disassembly

Ninety percent of all carburetor problems come from dirt and fuel gums. Before disassembling a carburetor, wash it thoroughly in clean solvent. A clean, well-lighted working surface is essential to good carburetor repair. The following tools will be most useful at the carburetor repair bench:

Soft-Jawed Vise
Needle-nose pliers
Asst. Screwdrivers
Spray carburetor
cleaner
500-500 Tool kit

Pen light
Magnifying glass
Compressed air
Small Ballpeen hammer
57-11 Pressure Tester

Totally disassemble the carburetor. Use the illustration in your catalog as a guide to ensure you've removed everything. Not every part shown on the breakdown will be included in your particular carburetor. The best cleaner for Walbro carburetors is a spray type carburetor cleaner. The pressure in the can works to dislodge dirt, and the chemicals aren't as caustic as the dip tank cleaners. If a dip cleaner is used, all plastic and rubber must be removed from the carburetor, and the carburetor should not be soaked for longer than 15 minutes.

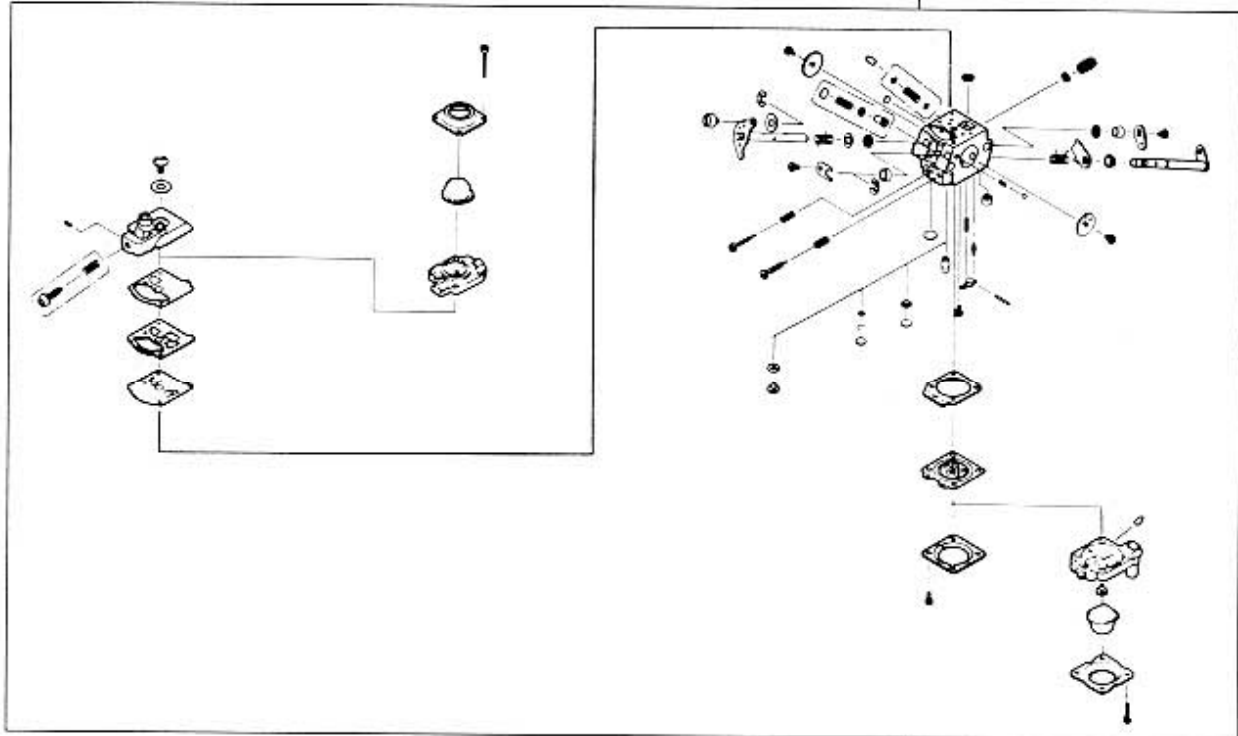

Mixture Screws

Inspect the tips of the mixture needles; they should be free of grooves. A ring you can see is ok, but you shouldn't be able to feel it with your fingernail. Be aware that if the needles are grooved, their seats will be ruined also. A damaged screw or seat results in a very sensitive needle. If the carburetor seems hard to adjust, always too rich or too lean, the needles and the seats are probably ruined.



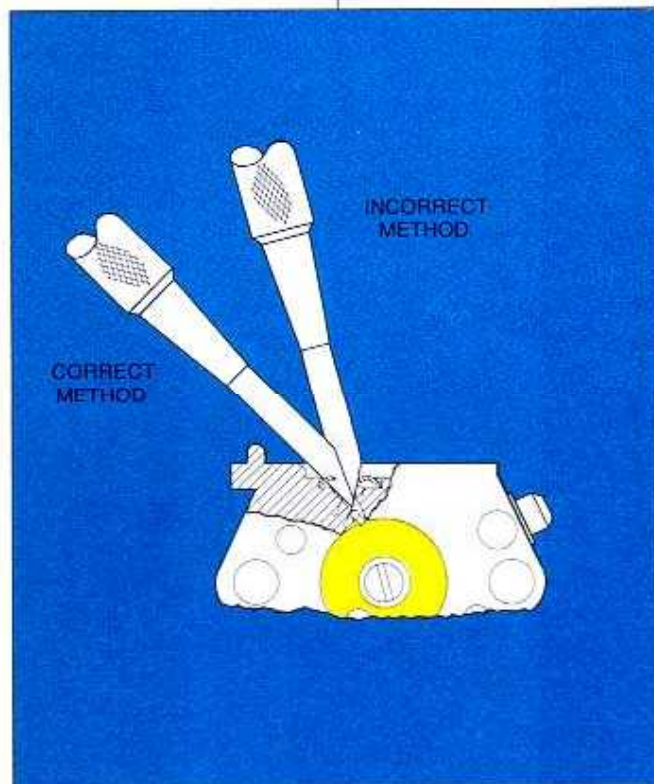
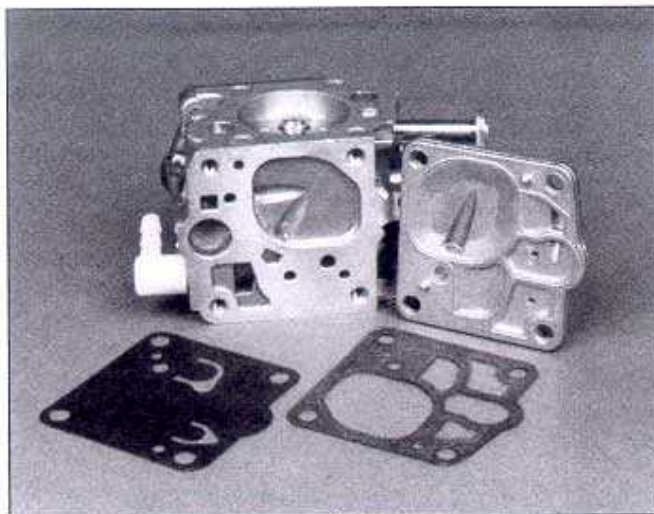

Fuel Pump

The fuel pump is generally trouble free. But here are some problems that can arise. 1. The diaphragm check valves can get stuck down by fuel gums and varnish, preventing fuel flow through the carburetor. 2. The crush ribs in the cover that seal around each chamber can get damaged by rough treatment, allowing the fuel pump to leak or reducing its capacity. 3. The machined surface where the check valves seal can get scratched or nicked; if this happens the valves may not hold and pump capacity may be reduced or the pump may empty of fuel during storage requiring excess cranking time to re-prime.

Welch Plug Removal

Removing the welch plugs is essential for a thorough carburetor service job.

Removing the welch plugs is best done with the Walbro 500-16 tool. Hold the punch at a shallow angle to the welch plug and drive it through. If the punch is not held at a shallow angle it could damage the calibrated passages underneath the plug. Spray carburetor cleaner through the idle passages under the plug or plate. **DO NOT** use a drill or other tools to clean the passages. These holes are precisely sized and changing them - even a thousandth - will effect the engine idle. When you are satisfied that all the passages are clean, rinse the carburetor in solvent and blow it dry.

Circuit Plate Removal

The circuit plate will be held in by one or two screws. Underneath the circuit plate will be a gasket and possibly a diaphragm. Take your time and follow the passages underneath the plate and gasket. Make sure you know where the fuel is coming from and where it is going to. Some carburetor kits have more than one circuit plate gasket in them. Make sure you use the proper gasket for your carburetor when reassembling it. If you use the wrong gasket, it will result in the loss of fuel flow to one or both circuits. If your carburetor had a circuit plate diaphragm, make certain that it gets put back in. **The circuit plate diaphragm acts as a main nozzle check valve.**

If the circuit plates or welch plugs are leaking, fuel will bypass the mixture screws and the carburetor will run rich.

Main Nozzle Check Valve

There are two types of main nozzles on Walbro carburetors: the mechanical seal and the capillary seal. The mechanical seal check valves can all be checked quite easily.

Locate the hole that supplies fuel to the main nozzle. This will generally be close to the high speed needle. Place the end of a piece of primer hose over the fuel hole; make sure the high speed needle is turned out a few turns. You should be able to easily blow through the valve into the carburetor throat, but not able to suck air back as easily.

If the hole is hard to reach with the hose, you can also plug the supply hole with your finger and hold the hose over the main nozzle needle hole. If the check valve tests okay, no further action is needed on it.

The capillary screen seals rely on the capillary action of gasoline against a fine wire screen to keep air from coming back through them at idle. Since there is no mechanical seal on these valves, they cannot be tested with the primer hose. Also, the capillary screen is susceptible to clogging with debris that has managed to pass through the inlet screen. Therefore, it is recommended that the welch plug or cup plug over the screen be removed so the screen can be cleaned and inspected. Refer to the carburetor parts list to see if the carburetor has a check valve screen.

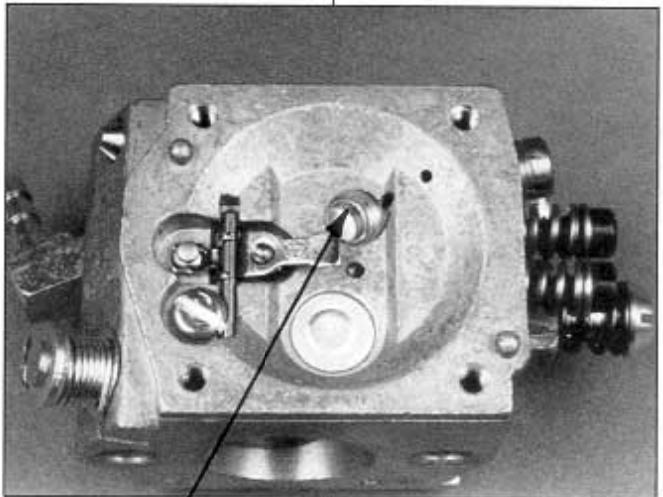
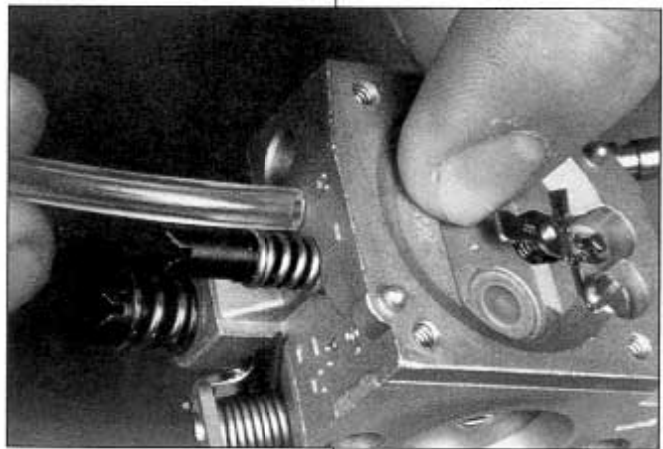
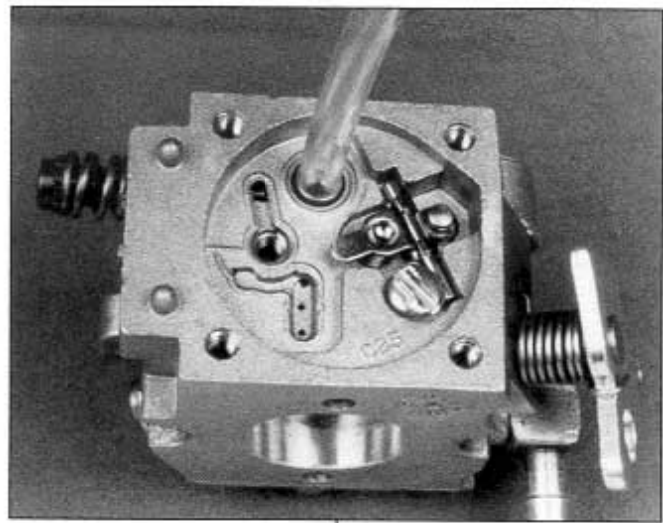

Cup plug over screen

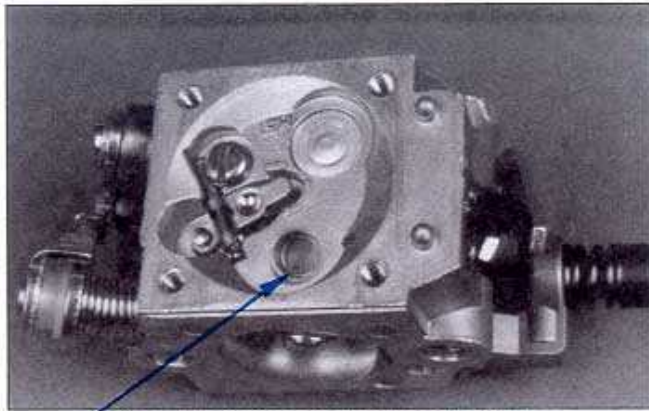

Cup plug removed, capillary screen visible.

Removing the cup plug to gain access to the check valve is best done with a # 8 bottoming tap or a 5mm set screw. Screw the tap into the cup plug, then pull the tap and plug straight out.



Walbro uses a number of main nozzle check valves. They are shown here along with the proper method of servicing them. NOTE: Before servicing the check valve, remove the high speed needle.

The most predominant check valve style in production now uses a capsule check valve. These are self-contained and are pressed into the carburetor body. If they need to be replaced, they are simply pressed on through into the carburetor throat. Some carburetors have a long tube nozzle; these must be pressed back out of the throat with a flat blade screwdriver.

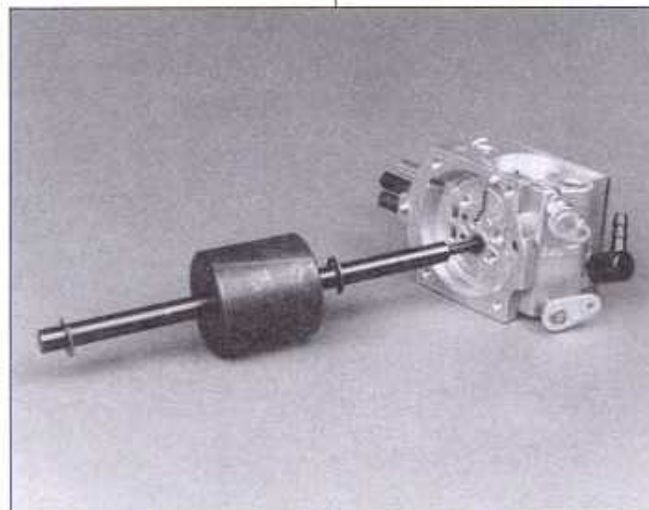

Older model carburetors such as the HDC contain a three piece check valve system. This consists of a check valve disc, a brass retainer and a debris screen. The retainer is removed with the slide hammer puller #500-501 in the 500-500 tool kit. Some HDB carburetors use a similar system but use the screen as a capillary seal.

Many WA model carburetors use a similar check valve retained with a smaller cap. This cap is serviced with the pin punch style tools in the tool kit. Tool 500-502 is used to remove the ring over the check valve disk, and 500-14 is used to reinstall it.

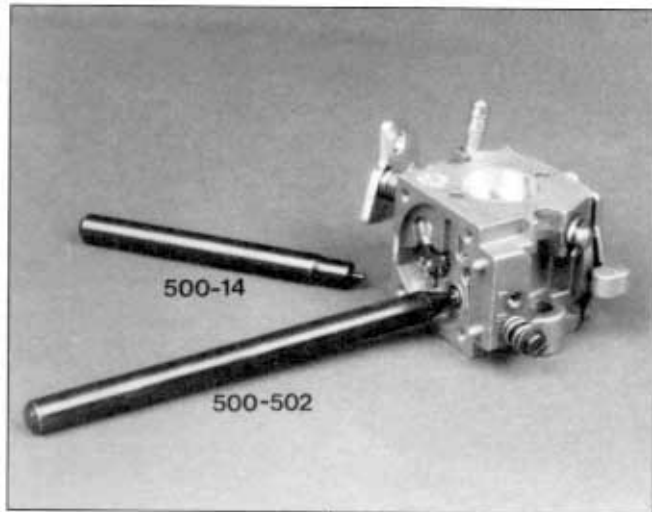

Circuit plate style carburetors may use a simple flapper style check valve incorporated into a small diaphragm under the circuit plate. Take care to install the correct circuit plate diaphragm, as the wrong one can shut off all the fuel through the carb.

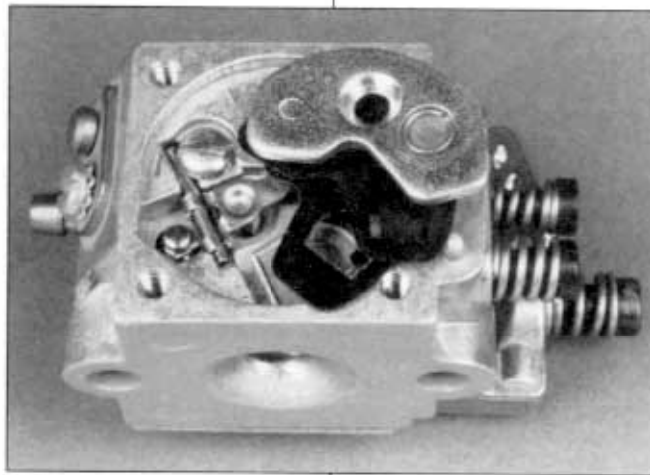

The check valves are generally trouble free, but they will get clogged up with fuel gums and should be removed before dip tank cleaning.

Inlet Seat

Soak a cotton swab in carb cleaner and use it to remove fuel gum from the inlet seat. Do not insert any hard tools into the seat as they can damage it. On a carburetor that has had a lot of use, eventually the inlet seat will become worn. When this happens, the needle will no longer hold pressure and the carburetor must be replaced. During cleaning, spray carburetor cleaner through all passages to ensure they are free of obstructions.

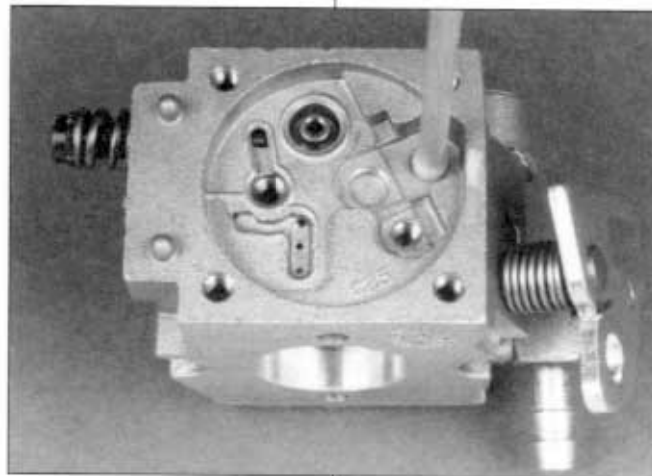

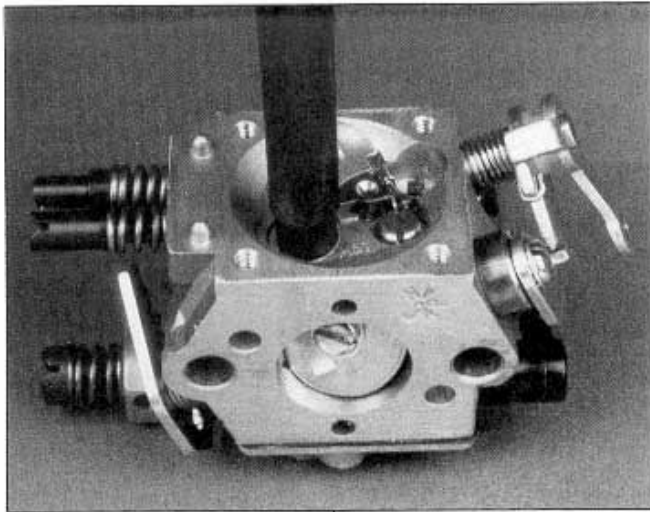

Carburetor Reassembly

To begin reassembly, install the circuit plate or new welch plugs. Lay the welch plug into its well; apply a thin ring of nail polish around the edge of the plug and drive it flat. Make sure the welch plugs are driven flat or they may interfere with the metering diaphragm movement. Wipe all the nail polish off the plug, to leave a thin ring around the edge. The sealant acts as an extra measure to ensure the plug doesn't leak. If the plug leaks you will notice that the idle needle becomes less effective. Tool 500-15 is the proper tool for welch plug installation.

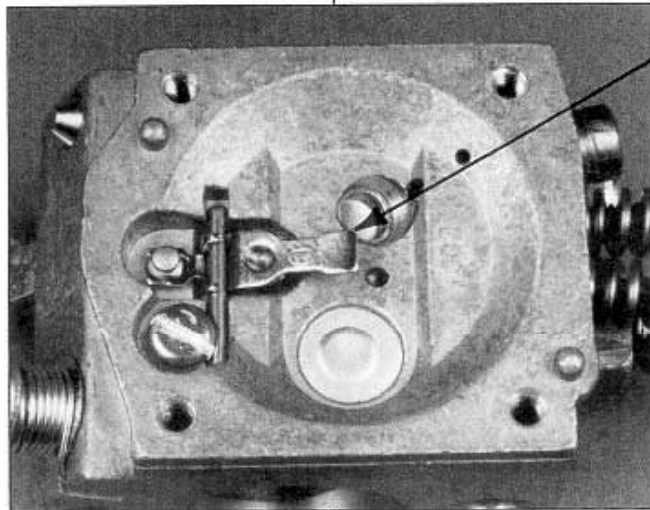

If the carburetor has a cup plug over the main nozzle, be careful to not install it too deeply into the main nozzle well. If pressed in too far, it can restrict the flow of fuel from the tip of the high speed needle. Press the cup plug in just far enough so its upper edge is even with the metering chamber floor.

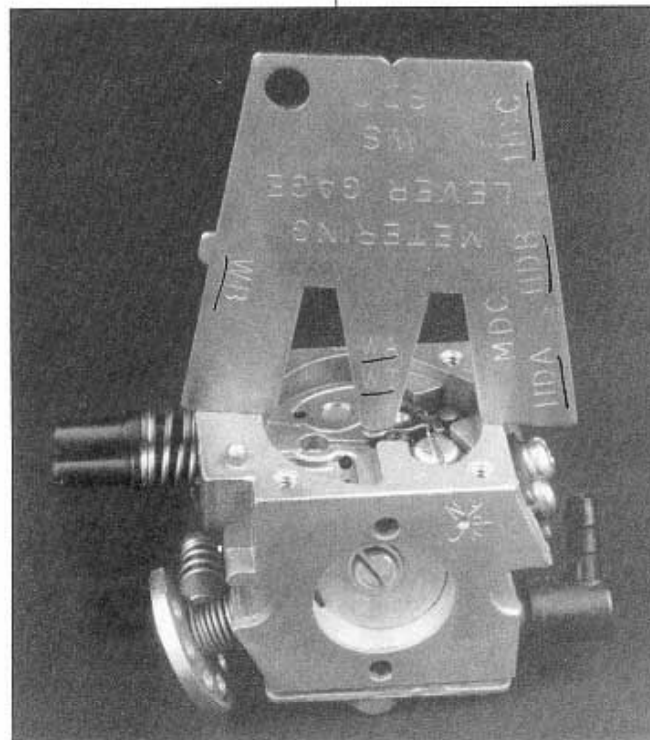

Next, reassemble the fuel pump. Install the inlet screen to the proper depth. Install new, original Walbro gaskets and diaphragms. Remember that the pump diaphragm goes on next to the carburetor body. Notice the crush ribs on the underside of the pump cover. These are essential for good sealing and should not be damaged.

Install the inlet needle, metering lever and spring. Set the metering lever height using the 500-13 gauge. This height is very important so make sure it is correct. If you are using an older gauge on a WZ or WY carburetor, use the gauge tab marked for the WA and WT carburetors.

Final Pressure Testing

Place a small amount of fuel in the inlet needle well. Now pressure test the carburetor again with the 57-11 gauge. Observe the pop-off and re-seat pressures. If the carburetor does not hold pressure, immerse it in solvent to determine where it is leaking. Small bubbles around the fuel pump cover are okay, but you should not get bubbles from under the inlet needle until the needle pops off. If it is okay, continue assembly.



Bubbles from under the inlet needle, only after pop-off.

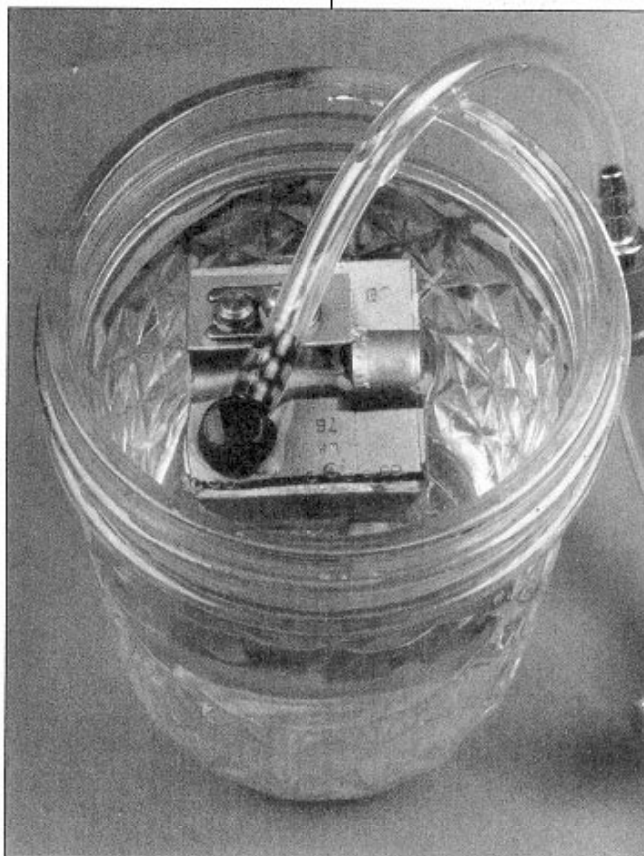

Small bubbles at the fuel pump gasket are not harmful.

PRESSURE TESTING

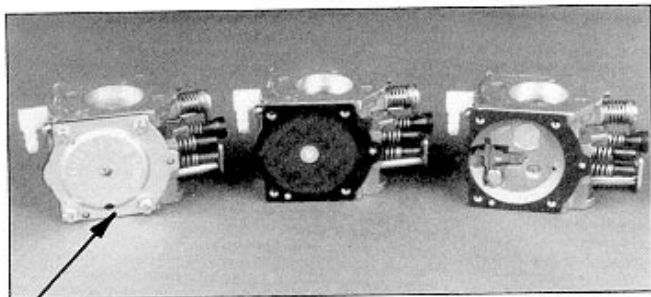

Install atmospheric vent so it faces away from cooling air, or so it faces down.

Install the metering gasket and diaphragm IN THAT ORDER. The metering diaphragm cover has a vent hole either in the center or on the side. It's important to install the cover so the hole is facing away from the engine fan. This way the hole does not get sawdust blown into it. If the fan does not blow across the carburetor, install the cover with the hole facing the normal downward position if you have a choice.

Your last step is to install and preset the fuel needles. LIGHTLY turn the needles in until they seat, then back them out 1 1/2 turns. This setting will be richer than the final adjustment. Final adjustment will be done with the engine running. Some engine manufacturers recommend a preset other than 1 1/2 turns; if so, follow their directions.

Final Adjustment

Idle Mixture:

The idle fuel mixture is usually adjusted first. Start the engine and let it reach its normal operating temperature. Begin slowly turning the idle mixture screw clockwise. As you turn it in, the engine speed will increase and then start to decrease as the mixture gets leaner. Note the needle position at the point when the engine speed starts to decrease; this is called the lean drop-off point. Back the needle out and the speed will again increase as the mixture passes through optimum toward rich. Note the position of the needle when the speed again starts to decrease; this is the rich drop-off point. Your final needle setting is halfway between the rich and the lean drop-off points. Once the mixture is set, the idle speed needs to be adjusted. Set the idle speed at the recommended R.P.M., or just below clutch engagement.

High Speed Mixture:

The high speed mixture is adjusted much the same way. With the engine at wide-open throttle, find the rich and lean drop-off points, and set the mixture between them.

WARNING: REMEMBER THE EFFECTS OF RUNNING AN ENGINE LEAN. RUN THE ENGINE FOR ONLY AN INSTANT AT THE LEAN DROP-OFF POINT.

If the engine seems to run rich at high speed when not under a load, check to see if it has a carburetor governor. See page 30 for information on Walbro carburetor governors. Once the carburetor is adjusted, re-check the idle speed and make sure the engine accelerates smoothly. If it stumbles on acceleration, enrich the idle mixture slightly. If poor acceleration still occurs, determine if the carburetor is equipped with an accelerator system and that it is working properly.

Barrel Valve Carburetors

The theories of operation of the barrel valve carburetor is very similar to that of the butterfly valve carburetor, but the actual operation is quite different.

In the butterfly valve carb, the throttle plate controls the air flow into the engine. To increase engine speed and power, more air is admitted to fill the cylinder. In order to maintain the proper air/fuel ratio for engine operation, the amount of fuel must increase or decrease in proportion to the amount of air. At higher air volumes the air flow through the venturi is adequate to draw fuel out of the main nozzle. The more air, the more fuel in fairly equal proportions. At lower engine loads, the engine is not drawing a lot of air. In fact, the air flows through the venturi easily without drawing fuel out of the main nozzle. At these low engine loads and speeds, we must provide fuel delivery at other points with higher manifold vacuums. These other delivery points are the idle and progression holes, where higher vacuum is created by the position of the throttle plate.

The barrel valve carburetors use a mechanical control over the fuel flowing into the intake air rather than relying on the air flow alone to control it. The barrel still regulates the air flow like a throttle plate, but instead of fuel entering the air stream at the main nozzle and three or four progression holes, the fuel enters the air stream from only one spot - the fuel nozzle. Since the barrel restricts the air flow both before and after the main nozzle, the main nozzle is always acted upon by the same amount of vacuum, essentially a variable venturi. A moveable needle in the fuel nozzle controls the fuel flow at all throttle settings. The needle moves into the fuel nozzle at low throttle and out of the nozzle at wide-open throttle. The needle movement is controlled by the throttle ramp. The advantage of the barrel valve design is that it provides for a very even air/fuel mixture throughout all throttle settings. Presently, there are two model classifications in the barrel valve line: the WY's and the WZ's. The WZ's are characterized by the presence of a built-in air cleaner, and the air flow through the carburetor makes a 90-degree bend. The WY's have the most diversity. There are currently eight WY models: WY, WYE, WYJ, WYK, WYL, WYM, WYP, and the WYF (which is a float-style carburetor). The WY's all have the fuel pump and the metering diaphragms stacked on one side of the carb body. Some of the WY's have metal bodies, some have plastic bodies. Most are fixed jet carburetors, but the WZ and some WYK's have adjustable main jets. Despite this variety, the WY's all operate in much the same way. As the throttle lever is rotated by the throttle cable, the hole within the barrel comes into alignment with the hole through the carburetor body. At the same time, the throttle pin follows up the ramp under the throttle lever. The pin, rising up the ramp, lifts the barrel and the fuel needle so that the needle exposes more of the slot in the side of the nozzle to the air stream.

The Operation of the WY

The fuel pump passages are cast into the body. Crankcase impulse is delivered to the fuel pump diaphragm through the passage to the lower right of the throat. The fixed jet is pressed into the body and sealed with an O-ring. Notice how the tabs of the plate, gaskets and the diaphragm stack up in a stair-step pattern as the carb is assembled. The pump cover is the floor of the metering chamber. It contains the inlet screen, the inlet needle and seat, and the metering lever and spring. The metering gasket, diaphragm, and cover complete the carburetor assembly.

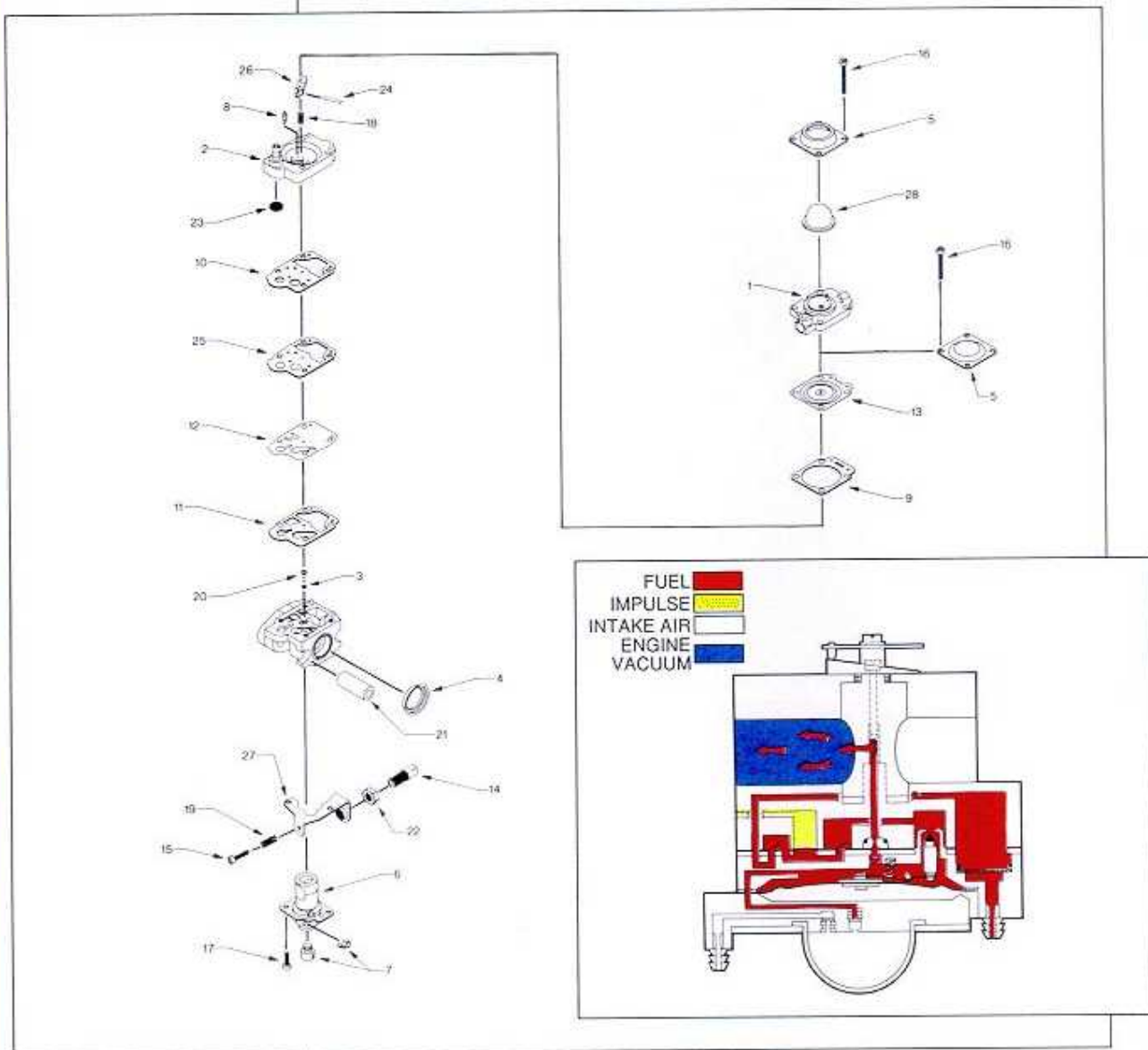

In operation, the fuel is drawn into the carb throat from the fuel nozzle, through the jet, and actually travels up through the center of the pump diaphragm stack, from a hole under the metering lever. The engine vacuum draws the metering diaphragm down onto the metering lever, which overrides the metering spring allowing the inlet needle to lift off its seat. The fuel is pushed through the inlet seat by the fuel pump.

The WZ Carburetor

The WZ is unique in the way the air flows through it. It also has an adjustable high speed mixture needle and an integral air cleaner. The fuel pump and metering diaphragm are on separate sides of the carb body. On the WZ, the fuel pump cover also houses the primer system.

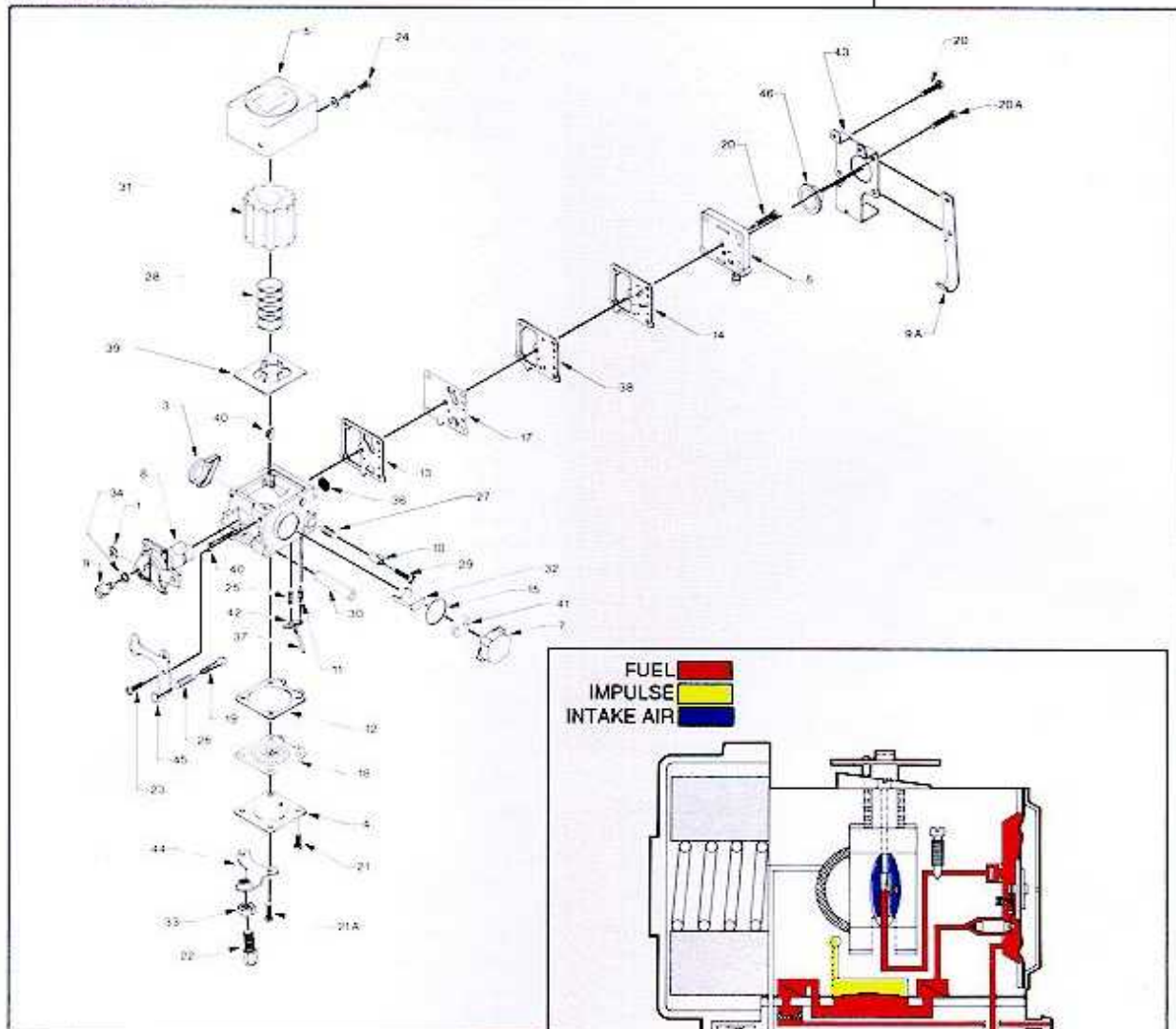

In operation, the fuel is drawn from the nozzle into the air stream. The fuel comes from the metering chamber through the nozzle check valve (which works with the primer and is pressed into the floor of the metering chamber). Fuel drawn from below the metering diaphragm allows the inlet needle to open and the fuel pump refills the chamber.

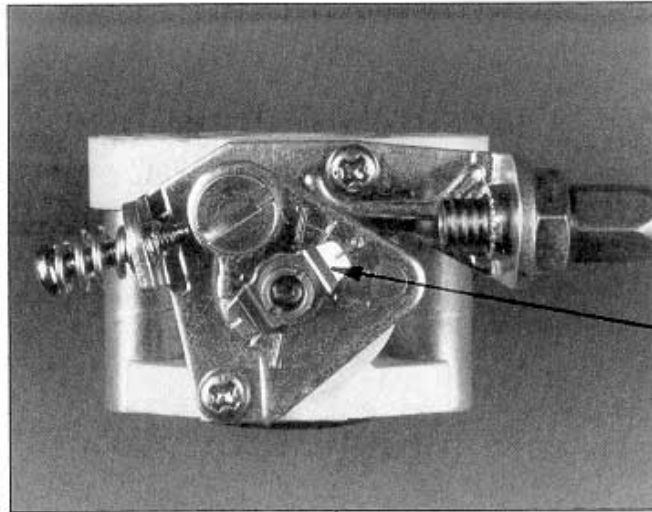

Adjusting the Mixture

Idle:

Some of the barrel valve carburetors have an idle mixture limiter screw on top of the throttle lever. Before adjusting the idle mixture, the limiter should be in the center of its travel. This outer screw makes very small mixture adjustments. Many WY carburetors do not have this limiter.

IDLE MIXTURE LIMITER
AT CENTER OF ITS TRAVEL.

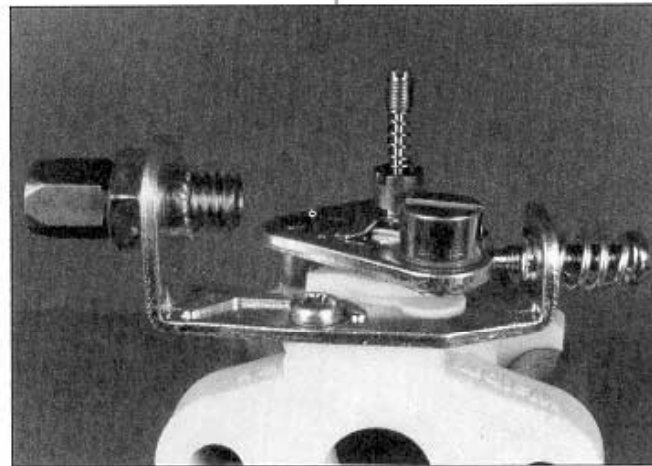

The fuel needle adjustment screw is located down inside the center of the barrel and may be covered with a plastic cap or may even be sealed with silicone. If the screw has not been disturbed, adjustments are generally not needed. If you have no idea where the screw is presently set, preset it by turning it all the way out until the threads disengage, then back 5 turns for the WY Series or back 6 turns for WZ's and 15 turns for the WYJ, WYK, WYL, and WYE. Turn the idle speed screw in until the carburetor is at approximately half throttle. Start the engine and adjust the idle mixture screw to obtain the highest R.P.M. Allow the engine to warm up and then close the idle speed screw down to 3000 R.P.M., or the point just before clutch engagement. Adjust the mixture to the highest R.P.M. again, then turn the mixture screw an additional 1/4 turn counter-clockwise. (Counter-clockwise=richer)

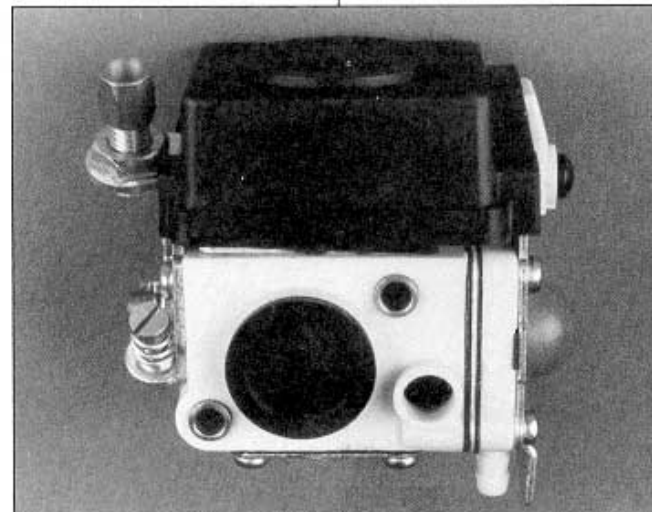

High Speed:

The WZ's and a few of the WY models have a high speed mixture screw. The preset is 1 1/2 turns. At wide open throttle the mixture should be adjusted to the midpoint between rich and lean.

There are several different fixed main jets available for the WY. If, due to your operating altitude you need to change jet sizes, look in the jet section of the price list for the various sizes.

NOTE: Some WYK carburetors have an adjustment screw that will produce a "richer only" mixture; you may not notice a lean drop-off on these carburetors.

Air Purge Systems

The air purge is often mistaken for a primer. But while a primer injects the fuel into the carburetor throat, an air purge system simply removes the air from the fuel passages so the carburetor and fuel lines are full of fuel. Air purge systems are being installed on many Walbro carburetors to promote easier starting of the engine.

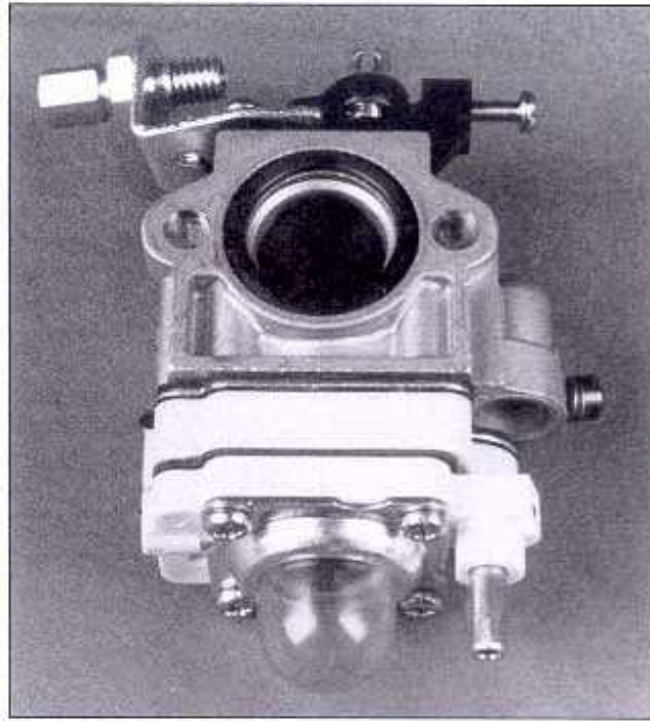

WYK with enriching mixture screw.

The heart of the air purge system is the bulb. The rubber bulb is generally mounted on the carburetor, but it can be mounted separately if the customer so desires. The bulb works in conjunction with a series of one-way check valves. On some older systems, the check valves are two clear plastic discs with springs holding them closed. These valves are located directly below the bulb.

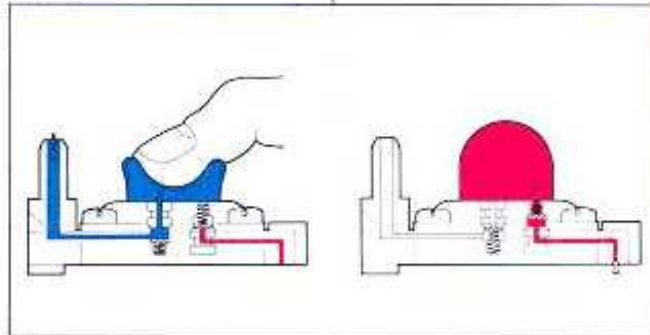

Depressing the bulb forces air through the discharge valve and out a tube back to the fuel tank.

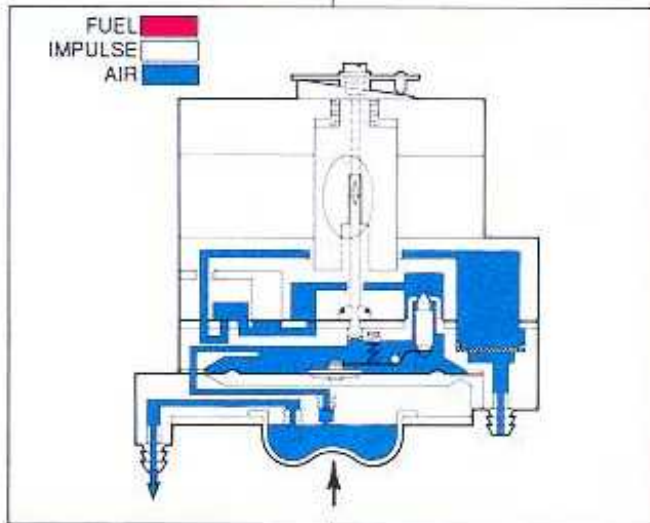

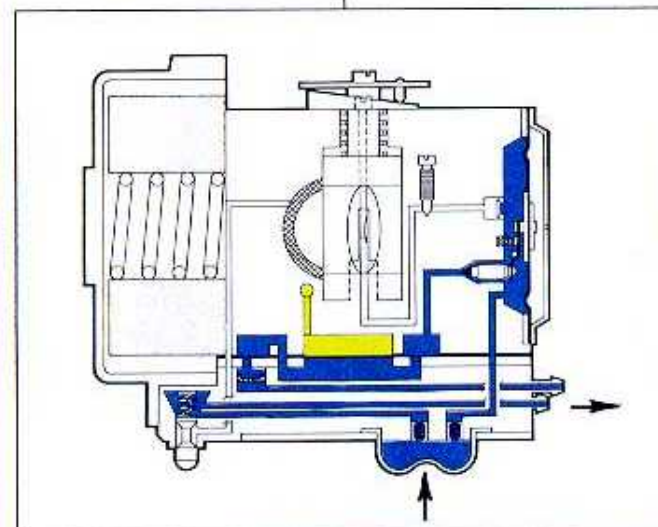
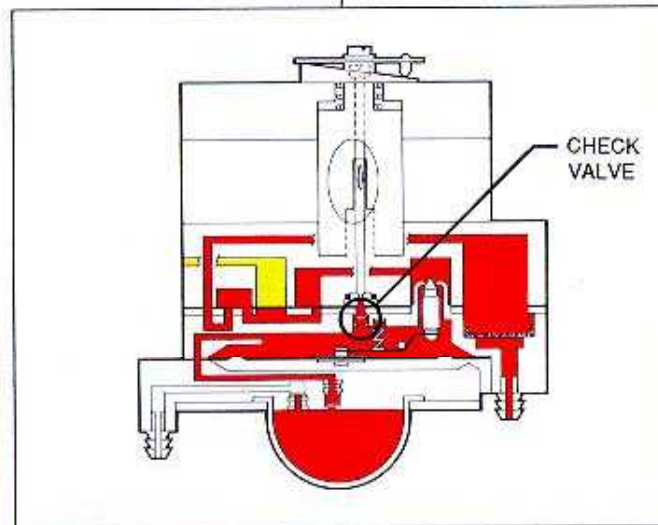
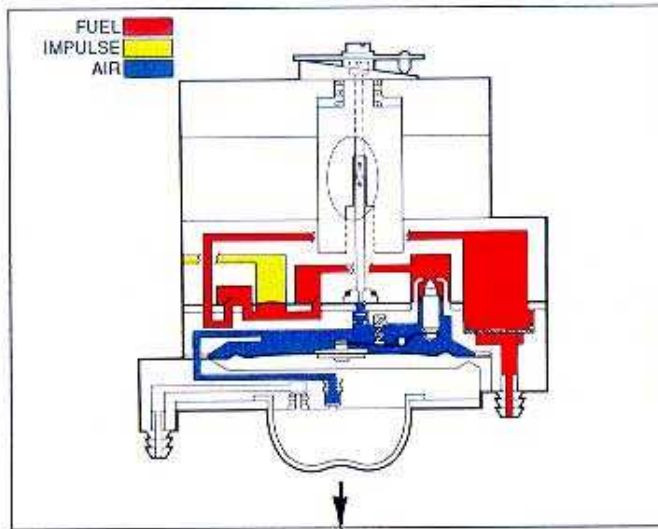

Depressing the bulb forces air out the overflow tube.

Releasing the bulb closes the discharge valve and opens the inlet valve. The vacuum travels through a channel and into the metering chamber. Here it draws down on the metering diaphragm, opens the inlet needle, and draws fuel from the tank through the fuel pump.

Once the bulb is full of fuel, all the air has been removed from the fuel system. One critical component to this system is the check valve located before the nozzle. This prevents air from coming in through the fuel nozzle when the bulb creates the vacuum in the metering chamber. A barrel valve carburetor does not need a check valve at the nozzle otherwise.

Newer air purge systems use a rubber double-acting check valve in place of the two spring loaded disc valves. The butterfly valve carburetor air purge system works the same way as the barrel valves. However, the third check valve prevents air flow back into the metering chamber from both the high speed and the idle circuits. These carburetors will still have a separate main nozzle check valve like all other butterfly valve carburetors.

Primer Systems

Presently only WZ and some WYK models have primer systems. The primer system works in much the same way as the air purge, but instead of simply pumping the fuel back to the tank it also pumps fuel into either a starter box or a starter wick. The starter wick is a porous foam wick that absorbs the fuel from the primer and makes it available to the engine at start up. The one possible problem with the primer system is the potential for flooding the engine if the bulb is pressed too many times. To overcome this problem, Walbro offers carburetors with a starter box. The starter box stores a metered amount of fuel so when the starter button is pressed, fuel is delivered to the starter wick. On WZ's the starter wick is located behind the intake cup. WYK carburetors use a primer system with the starter wick under the bottom of the barrel. The WYK's with starter boxes have an additional spring loaded diaphragm that pressurizes the fuel being put into the starter wick.

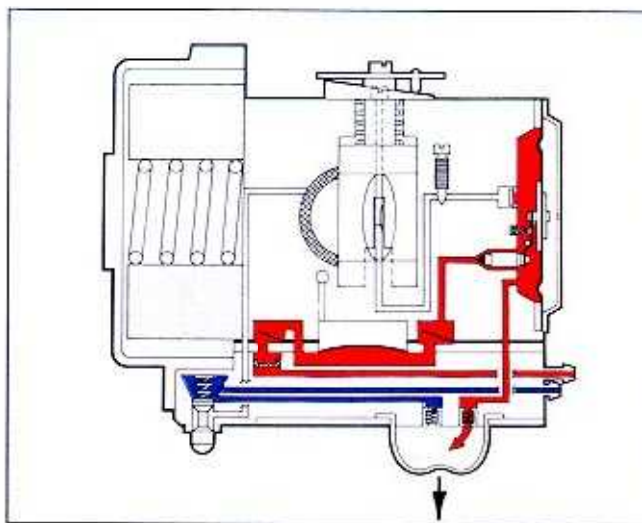

As the bulb returns to shape, fuel is drawn in through the fuel pump and the metering chamber to fill the bulb.

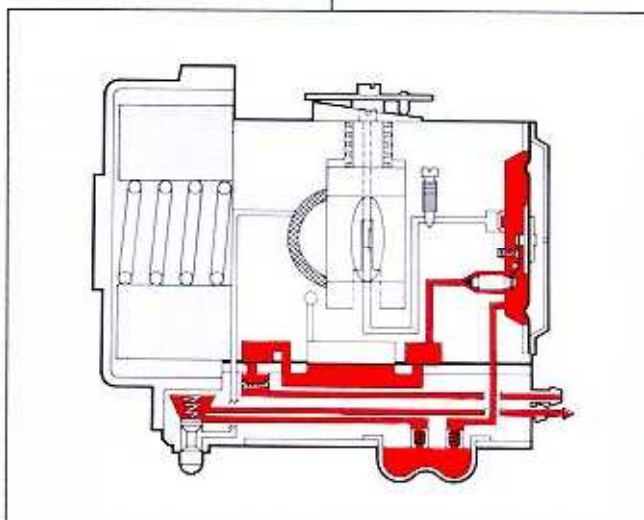

The next time the bulb is depressed, fuel is pushed into the starter box and out the overflow. On carburetors without the starter box, fuel flows to the starter wick directly from the bulb.

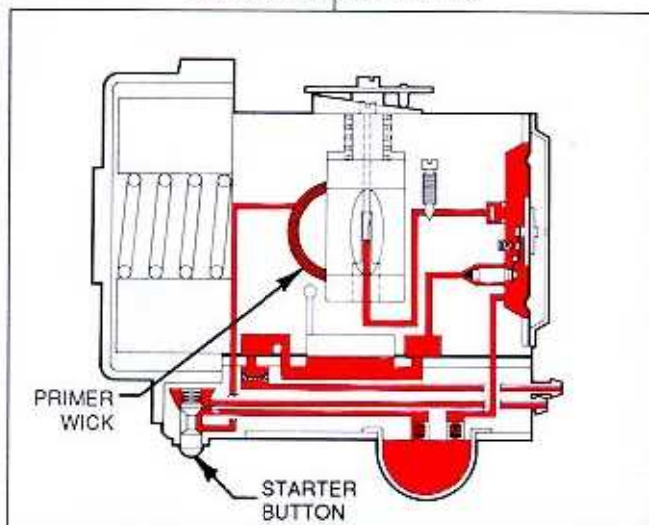

On starter box equipped carburetors, the fuel is diverted to the wick only when the starter button is pressed.

Troubleshooting the primer and air purge systems is generally only a matter of cleaning and servicing the check valves and the bulb. The bulb should be pliable and free of cracks. If it is stiff or brittle it will not function. The check valves can get stuck with fuel gum or debris. If the bulb feels like it cannot be depressed, the discharge valve or the return line back to the fuel tank is plugged or kinked. If the bulb does not spring back into shape, the inlet check valve is probably stuck closed, or the fuel line is restricted. If the bulb constantly fills with air instead of fuel there could be a leak in the fuel system, or the discharge check valve or the nozzle check valve is stuck open. Any defect that prevents the carburetor from getting fuel to the engine will also prevent the air purge or primer from working (with the exception of the nozzle check valve); if it is stuck closed, the engine will not run but the primer will work. If it is stuck open, the engine will work but the air purge won't. If you suspect the check valve on a butterfly valve carburetor is sticking open and causing the bulb to fill with air, shut off both needles and then work the air purge. If the bulb now fills with fuel, the check valve needs to be cleaned or replaced. To replace it, simply screw a sheet metal screw into the center hole and pull the whole assembly out, then press a new one in. To test any check valve, determine the proper direction of flow through the check valves and test for it with the primer hose (like you did with the main nozzle check valve).

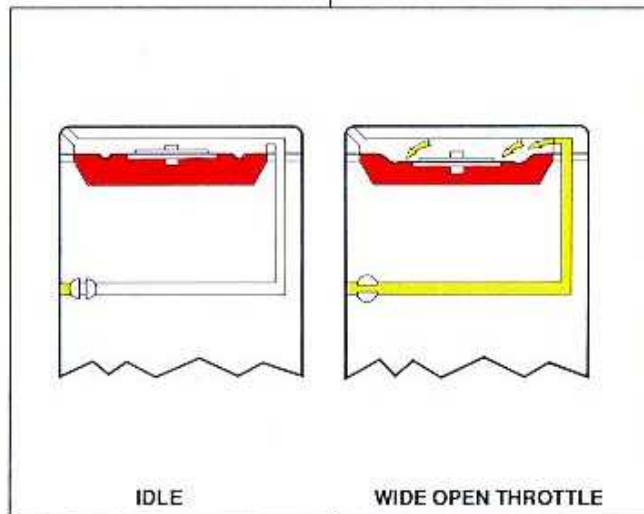
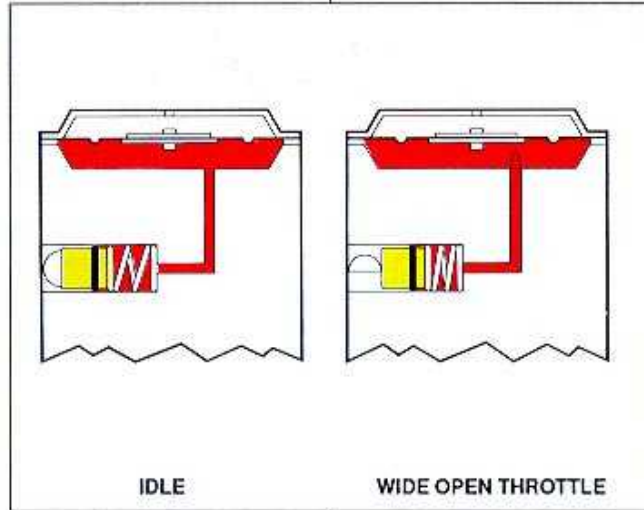

Accelerator System:

There are three styles of accelerator pumps found on Walbro diaphragm carburetors. All three are used to provide an extra shot of fuel to enrich the mixture when the throttle is first opened. The advantage of the accelerator system is that it allows the idle mixture to be set at optimum, rather than slightly rich, allowing the engine to idle better.

Piston Pump:

The piston pump system consists of a small brass piston in a cylinder, drilled into the carb body. The piston is held into a flat spot on the throttle shaft by a spring. When the throttle is opened the piston is lifted out of the flat spot and pressurizes the fuel behind it. The fuel is forced through a channel and is injected into the main nozzle or metering chamber.

Crankcase Impulse:

This system uses the pressure pulses from the crankcase to pressurize the metering chamber. A pressure passage (similar to the one that runs the fuel pump) is channeled up to a hole in the carburetor body. When the throttle is opened, a hole through the throttle shaft lines up with a hole in the body. This allows the pulse to travel into the chamber on the dry side of the metering diaphragm, forcing the diaphragm down and allowing the inlet needle to open.

Boot Style:

This system uses a small rubber bladder to hold a shot of fuel. The inside of the bladder is connected to the metering chamber, or directly to the carburetor throat. As in the impulse style accelerator, a hole leads from an impulse source through the center of the throttle shaft and into a small brass cap surrounding the rubber boot. When the throttle is opened, the impulse pressure is allowed to flow around the outside of the boot collapsing it and forcing fuel out of the inside of the boot and into the carb throat.

Troubleshooting the accelerator system is generally a matter of keeping the passages clean. If you are having trouble with engine acceleration, check for an accelerator pump and make sure it's operating.

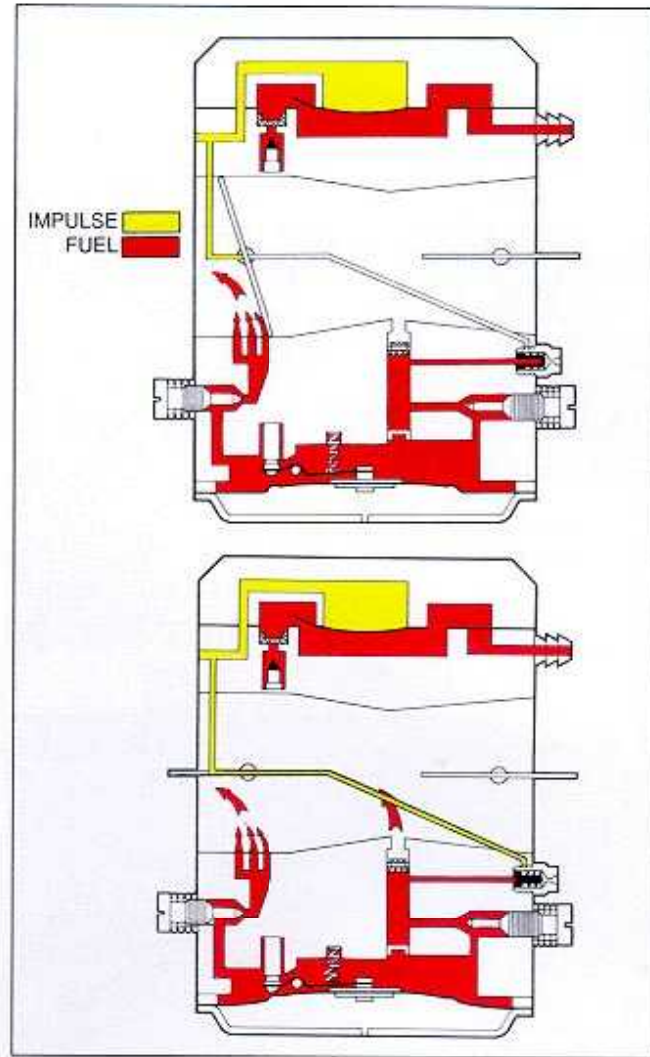

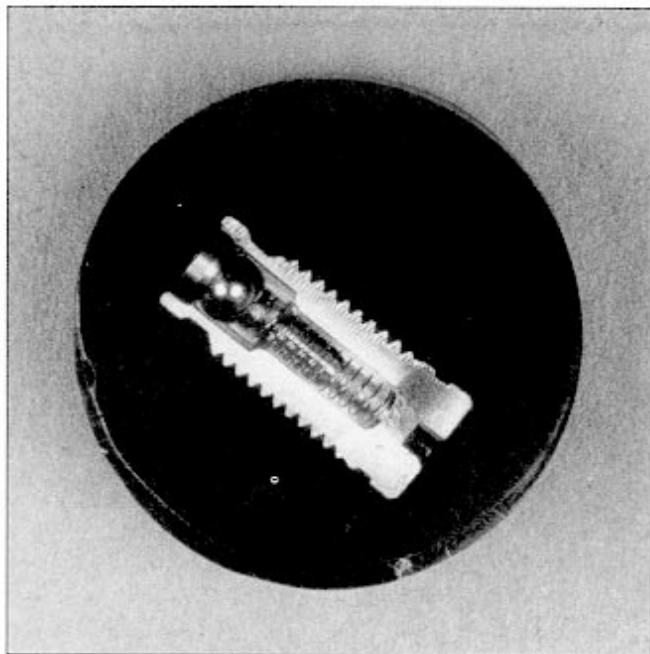

Cutaway of governor capsule

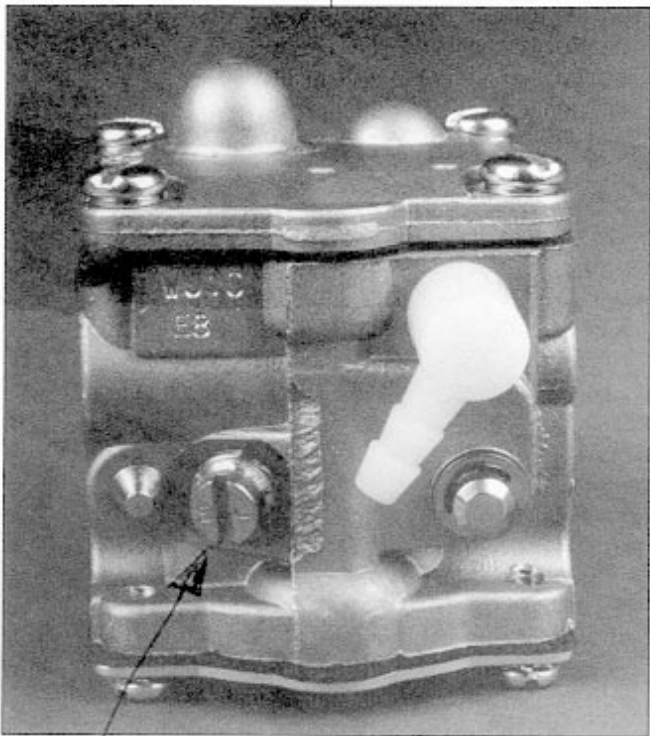

Governor installed in a carburetor

Governor Systems

The governor is another option available to Walbro customers. It works off the vibrations created in a running engine. The governor consists of a spring which holds a ball against a seat. When the engine exceeds its governed speed, the vibration of the ball overrides the spring. When this happens, fuel is allowed to bypass the ball and flows directly from the metering chamber into the carb throat. The rich mixture causes the engine to slow down.

Generally there is no service needed on the governor system. If you cannot get the mixture to lean out, make sure the governor ball is not stuck open. Keep in mind that the engine will act rich as it reaches its governed speed, so you will not be able to lean it out at no-load, wide-open throttle. To adjust the high speed mixture on a governed engine you will have to load down the engine to adjust the high speed mixture because on many engines the governed speed can be reached before the main nozzle is delivering fuel. This style governor system has also been incorporated into the main nozzle on some carburetors.

The proper tools add efficiency and professionalism to the carburetor repair job. The 57-11 pressure tester and the 500-500 tool kit are also available as a package; order the 400-595 from your distributor to receive both. Any of the tools in the 500-500 kit are also available separately from your Walbro distributor. The 57-11 pressure gauge pump can be rebuilt, using the K1-Gauge rebuild kit.

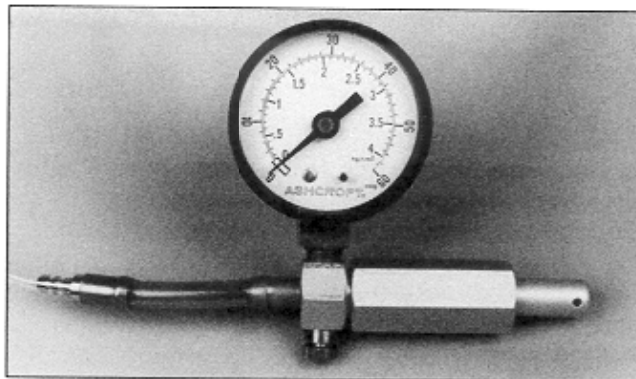

57-11 Pressure Tester

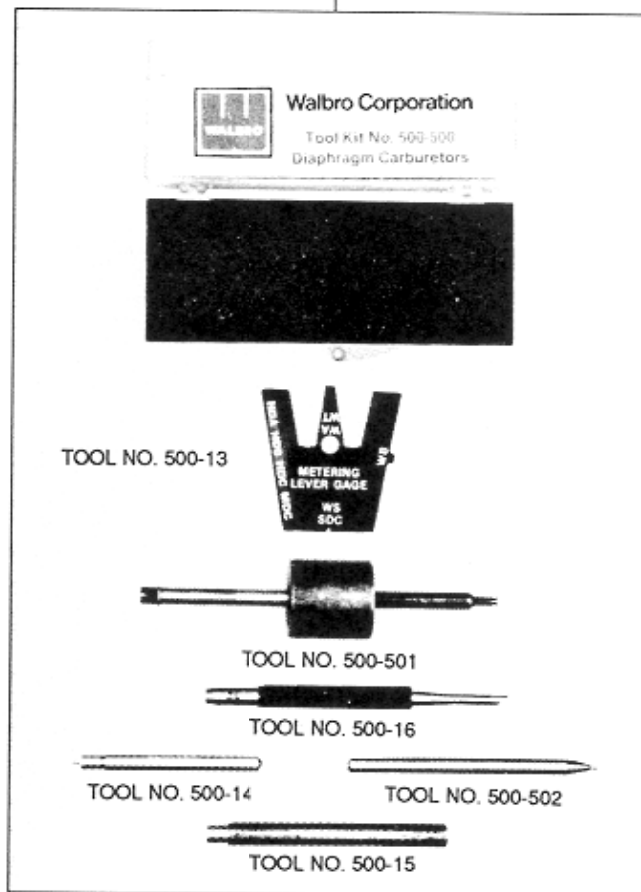

500-500 Tool Kit

TOOLS



Walbro
Engine Management
Aftermarket Division

6214 Garfield Street
Cass City, Michigan 48726-1325
Telephone (989) 872-2131
FAX (989) 872-3090